

PPGEE-6 DIMENSION

Unit dimensions (nominal dimensions in mm)

Nominal size 6

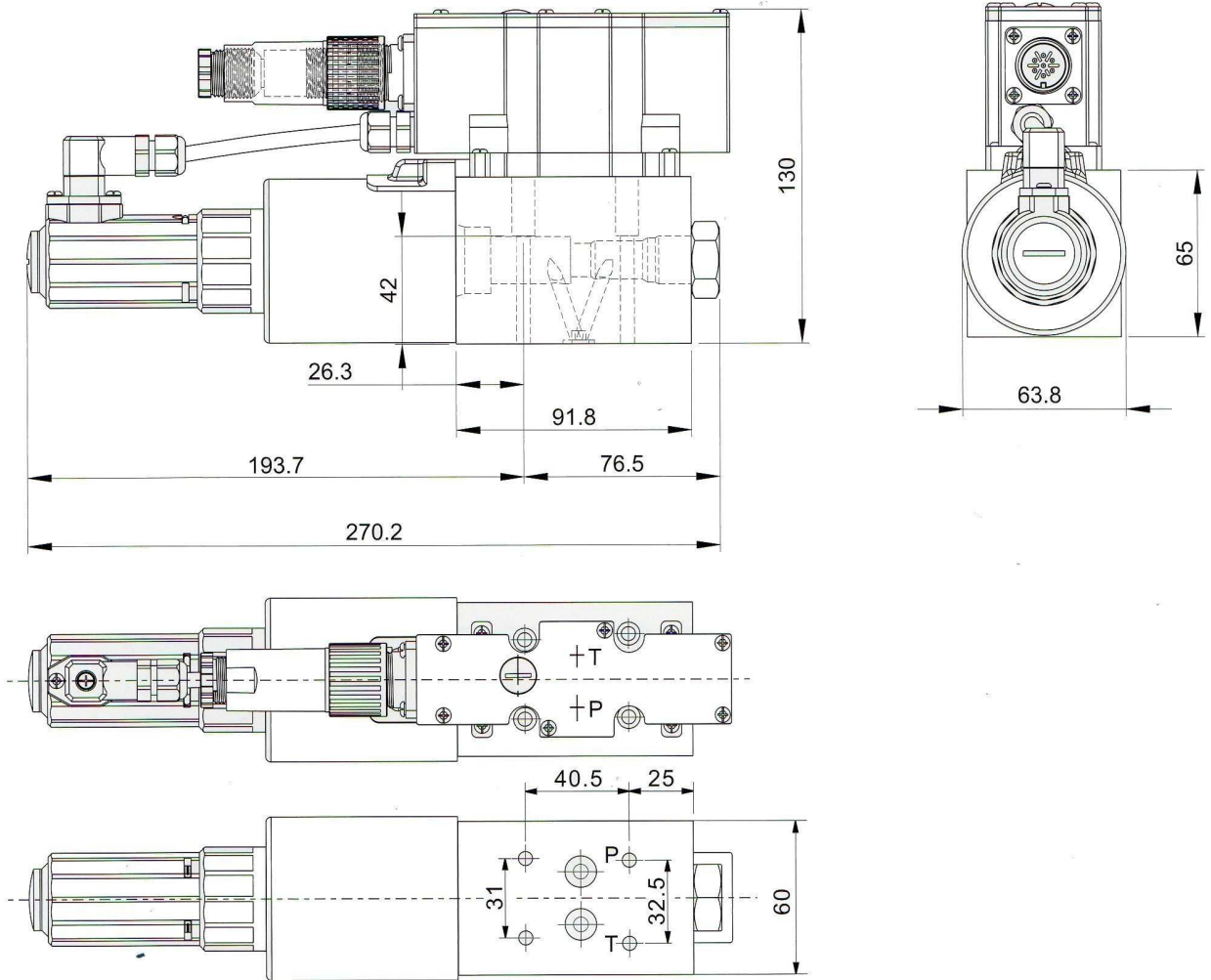

Subplate mounting

Nominal size 6

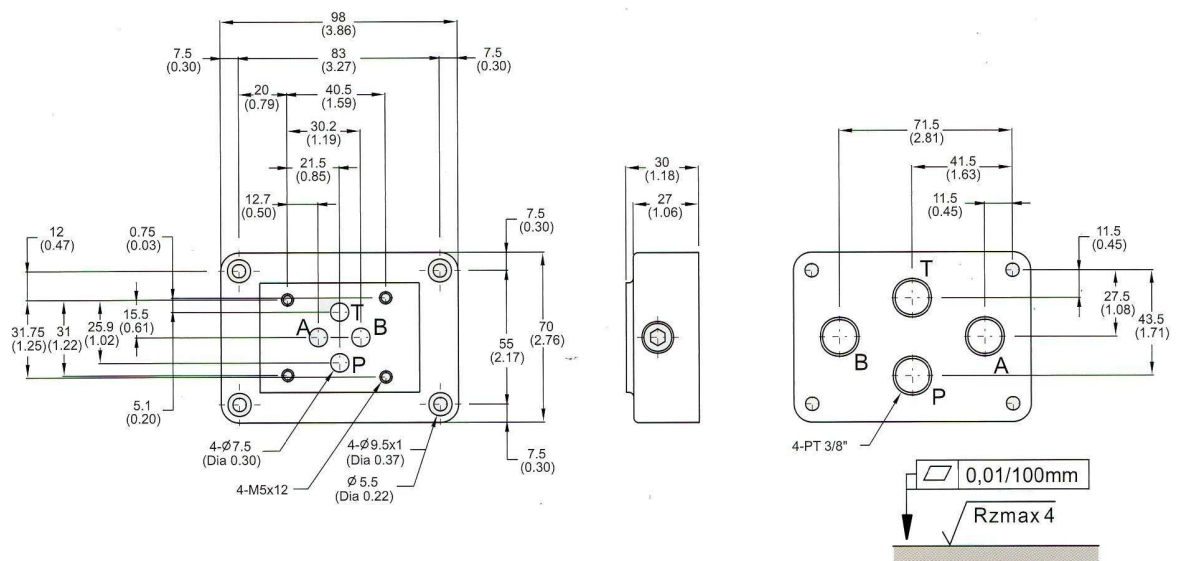

Required surface finish of the valve mounting surface

Tolerances to: - General tolerances ISO

- 規格修改，本公司不另行通知
- Specification is subjected to change without notice.