

# Dimensions

## PV016 ~ PV023,PV028(Body 1)

Metric version (Motor Mounting  $\varnothing 101.6$ )

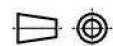
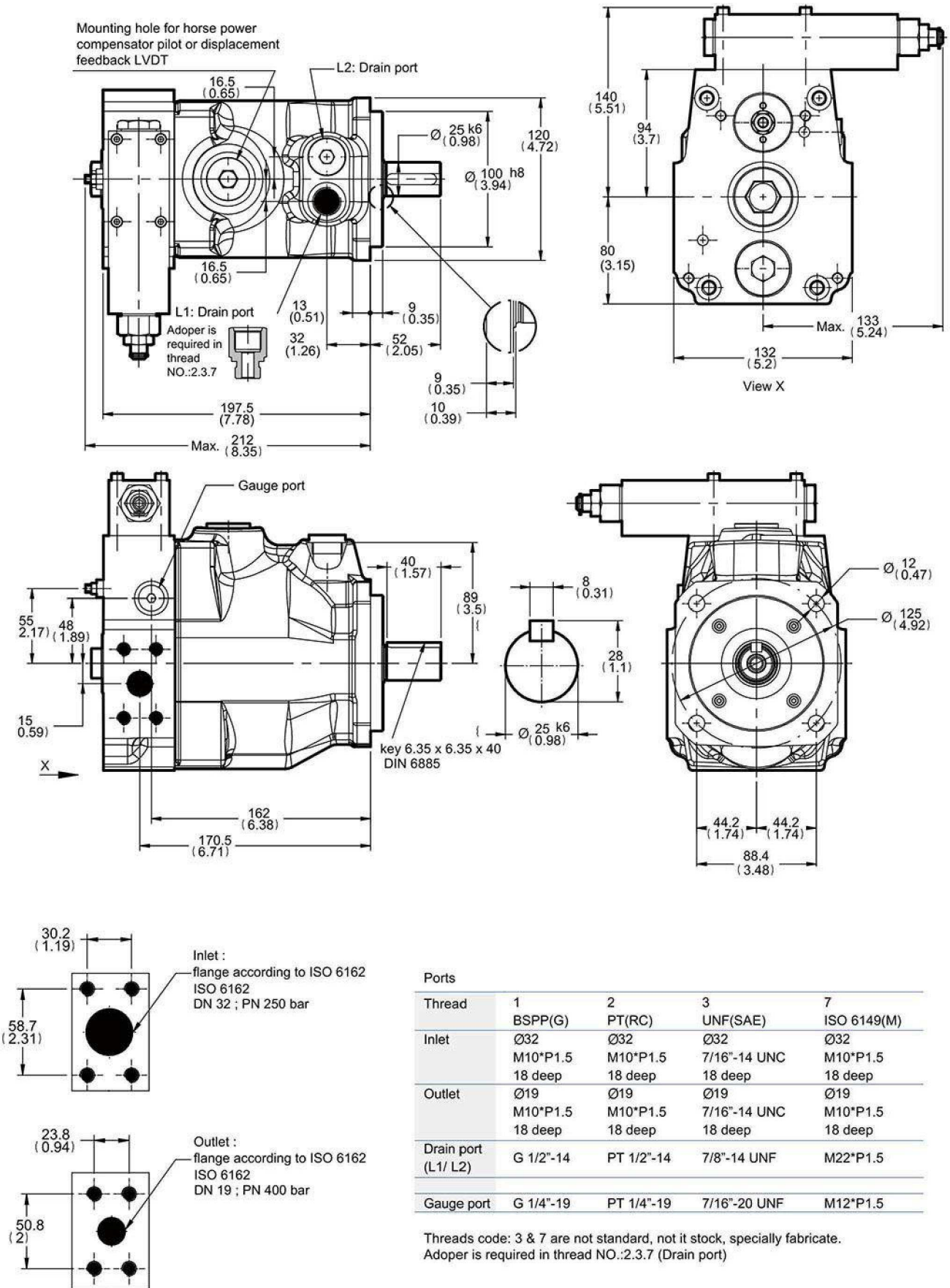

# Dimensions

PV016 ~ PV023, PV028 (Body 1)

Metric version (Motor Mounting  $\varnothing 100$ )

Shaft type

Mounting code: **M**

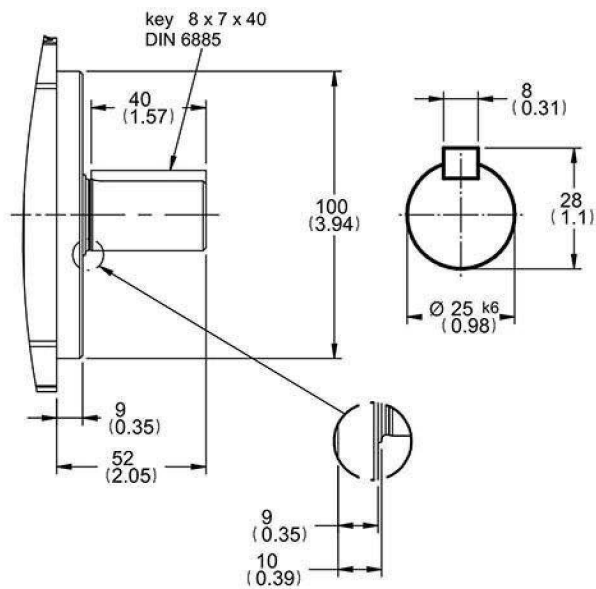

Mounting code: **R**

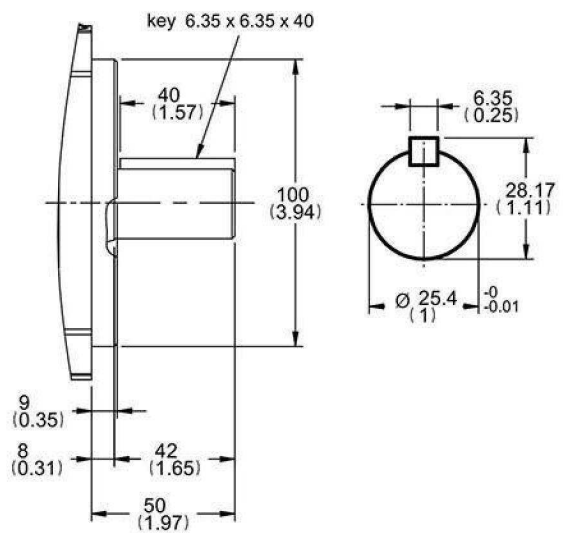

Mounting code: **K**

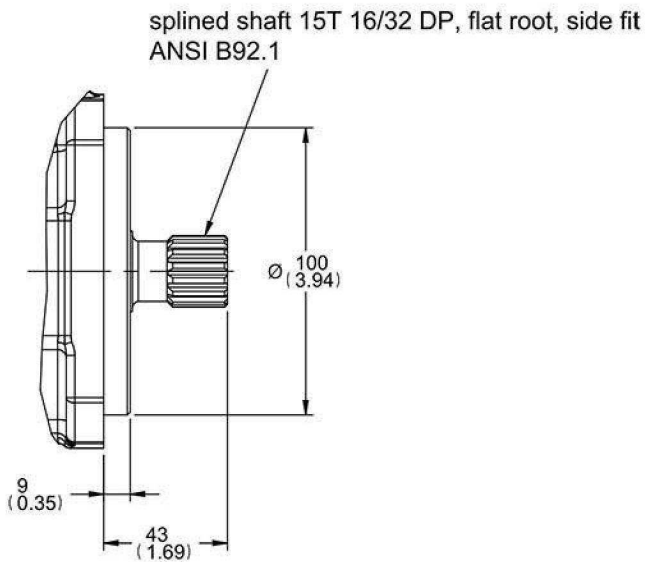

Mounting code: **S**

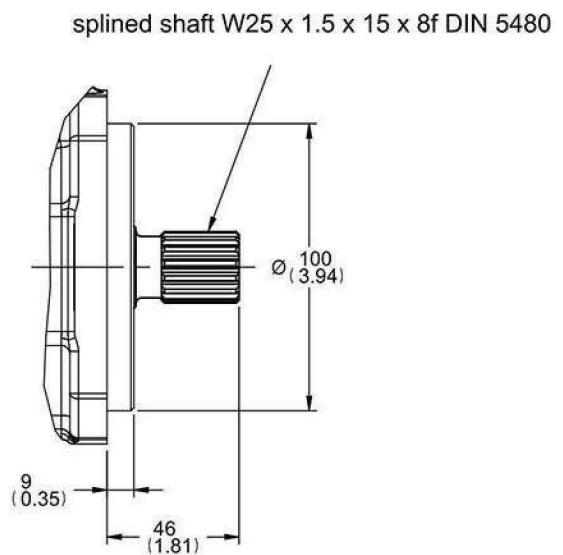

# Dimensions

## PV016 ~ PV023, PV028 (Body 1)

SAE version (motor mounting  $\varnothing 101.6$ )

Mounting hole for horse power compensator pilot or displacement feedback LVDT

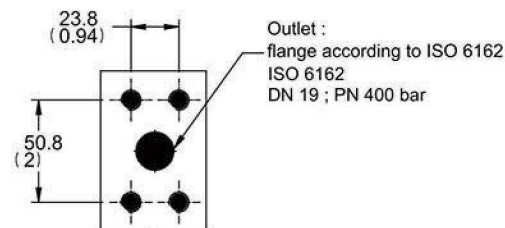
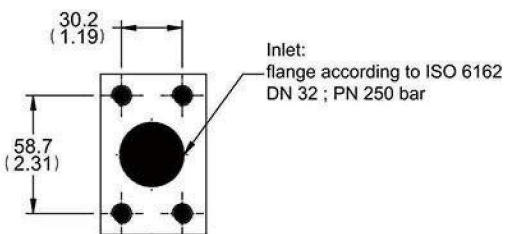
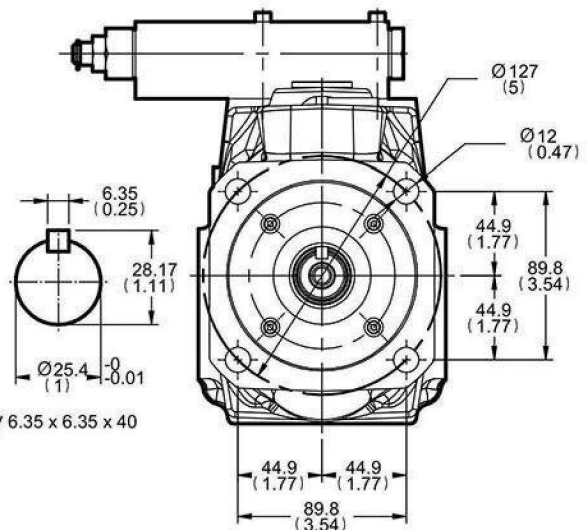
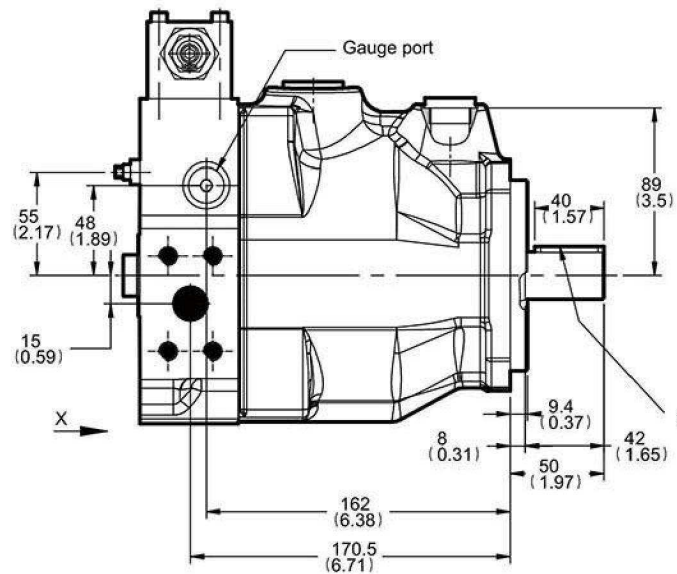
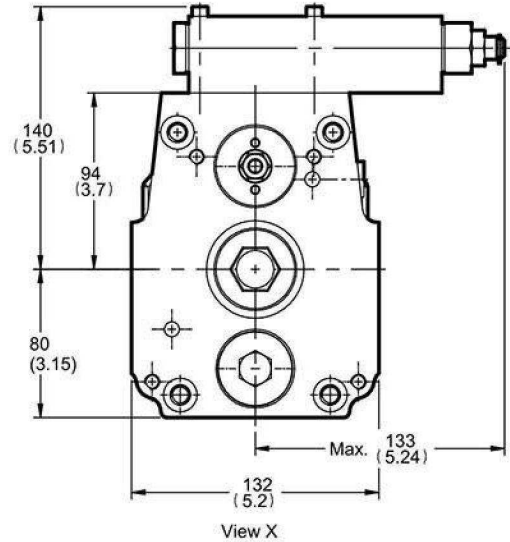
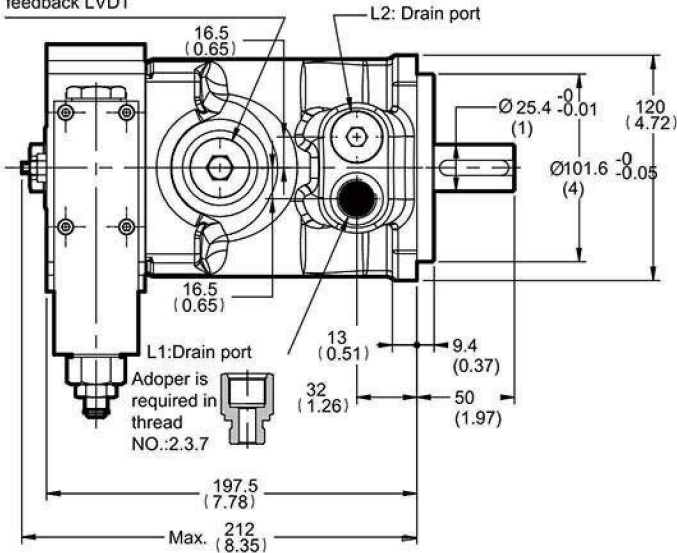

### Ports

Thread	3 UNF(SAE)	1 BSPP(G)	2 PT(RC)	7 ISO 6149(M)
Inlet	$\varnothing 32$ 7/16"-14 UNC	$\varnothing 32$ M10*P1.5 18 deep	$\varnothing 32$ M10*P1.5 18 deep	$\varnothing 32$ M10*P1.5 18 deep
Outlet	$\varnothing 19$ 7/16"-14 UNC	$\varnothing 19$ M10*P1.5 18 deep	$\varnothing 19$ M10*P1.5 18 deep	$\varnothing 19$ M10*P1.5 18 deep
Drain port (L1/L2)	7/8"-14 UNF	G 1/2"-14	PT 1/2"-14	M22*P1.5
Gauge port	7/16"-20 UNF	G 1/4"-19	PT 1/4"-19	M12*P1.5

Threads code: 3 & 7 are not standard, not it stock, specially fabricate.  
Adoper is required in thread NO.:2.3.7 (Drain port)

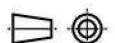

# Dimensions

PV016 ~ PV023, PV028 (Body 1)

SAE version (motor mounting  $\text{Ø}101.6$ )

Shaft type

Mounting code: **N**

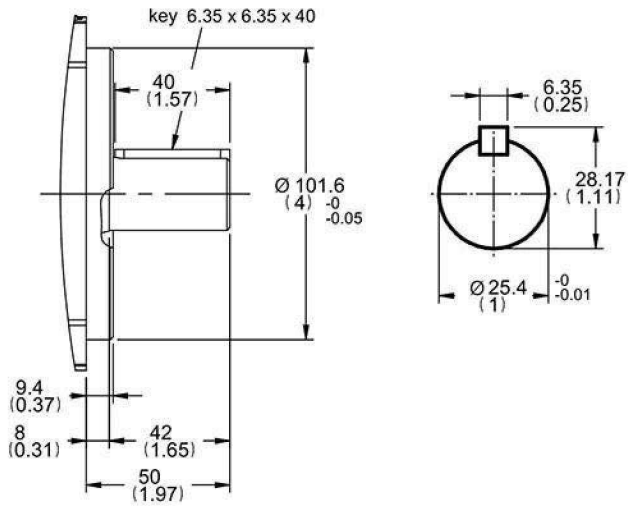

Mounting code: **J**

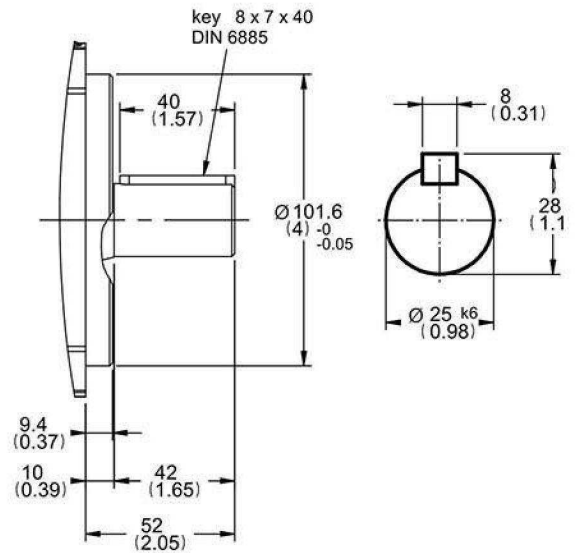

Mounting code: **D**

splined shaft W25 x 1.5 x 15 x 8f DIN 5480

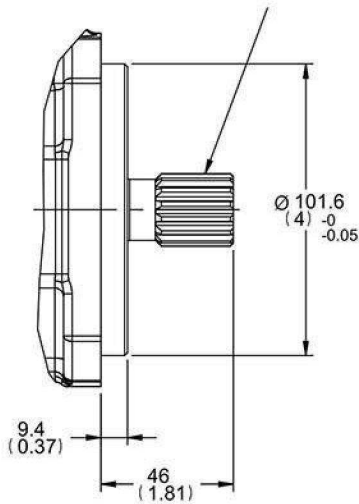

Mounting code: **U**

splined shaft 15T 16/32 DP, flat root, side fit ANSI B92.1

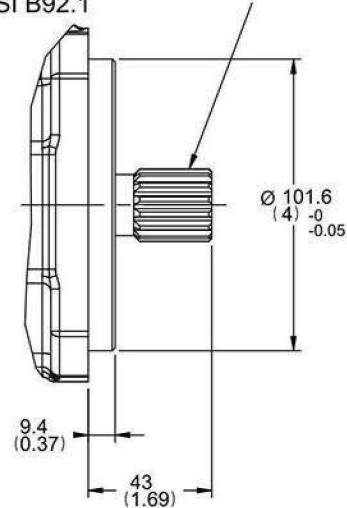

# Dimensions

PV016 ~ PV023, PV028 (Body 1)

Thru drive

Thru drive:

C, D, E, I, J, K

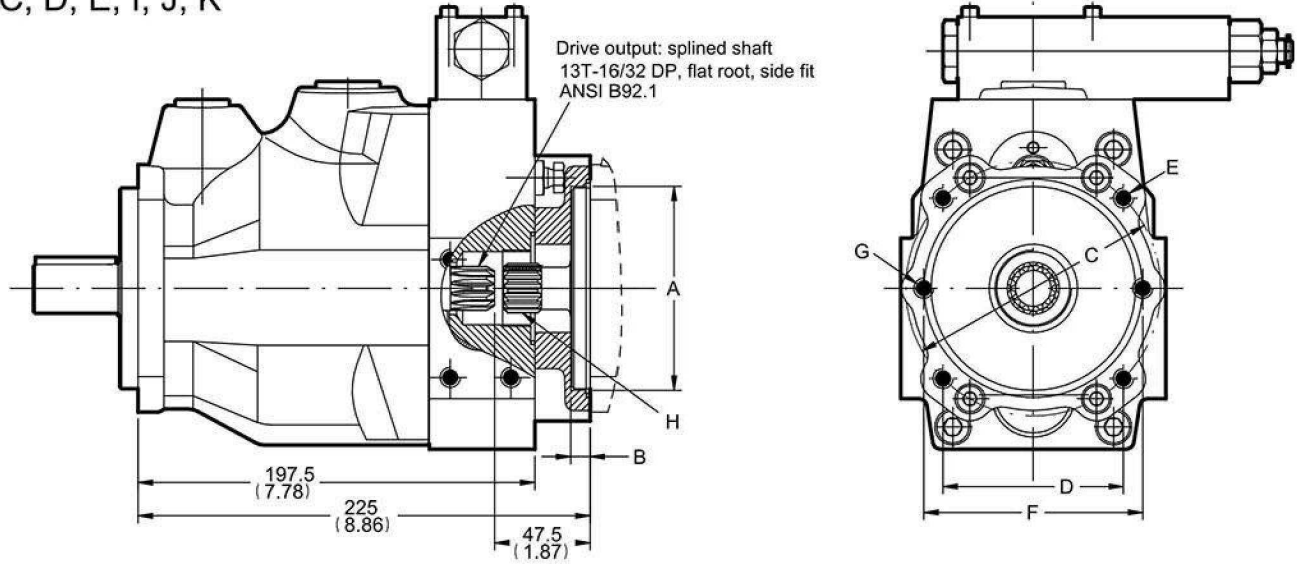

Thru shaft adaptors are available with the following dimensions

thru code	A	B	C	D	E	F	G
I	63	10	85	-	M8	100	M8
J	80	10	103	-	M8	109	M10
K	100	10.5	125	-	M10	n. avail.	n. avail.
C	50.8	10	-	-	-	82	M8
D	82.55	10	-	-	-	106	M10
E	101.6	10.5	-	89.8	M10	n. avail.	n. avail.

Thread codes are 3 and 7, the dimensions E and G are UNC-2B threads

threads code: 3 and 7 Not standard, not in stock, require special requests.

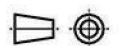

# Dimensions

## PV016 ~ PV023,PV028(Body 1) Inlet / Outlet Flange

### Inlet Flange

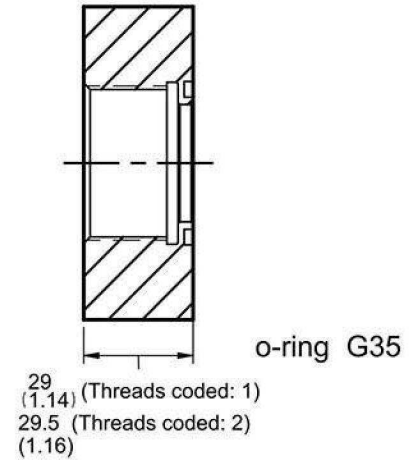
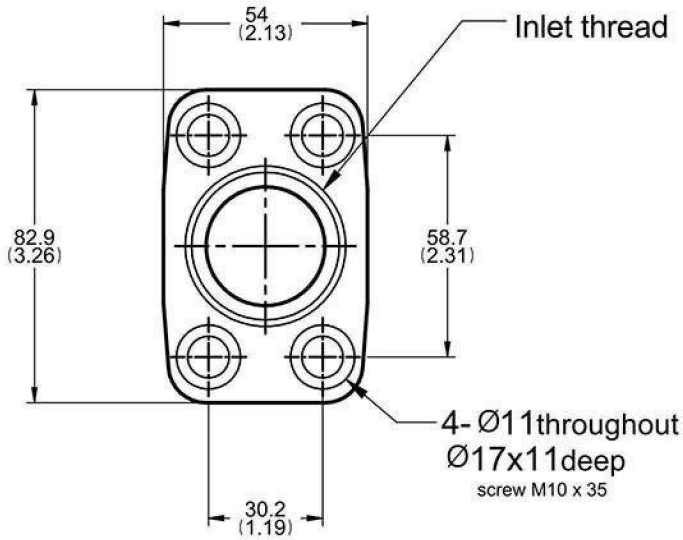

### Outlet Flange

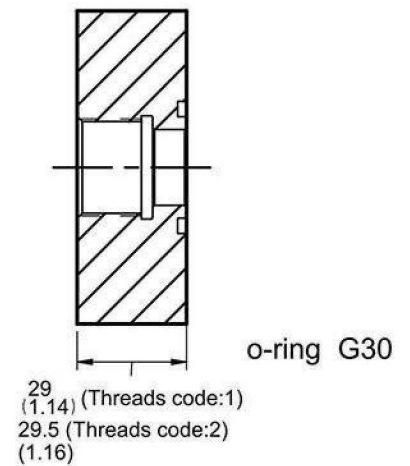
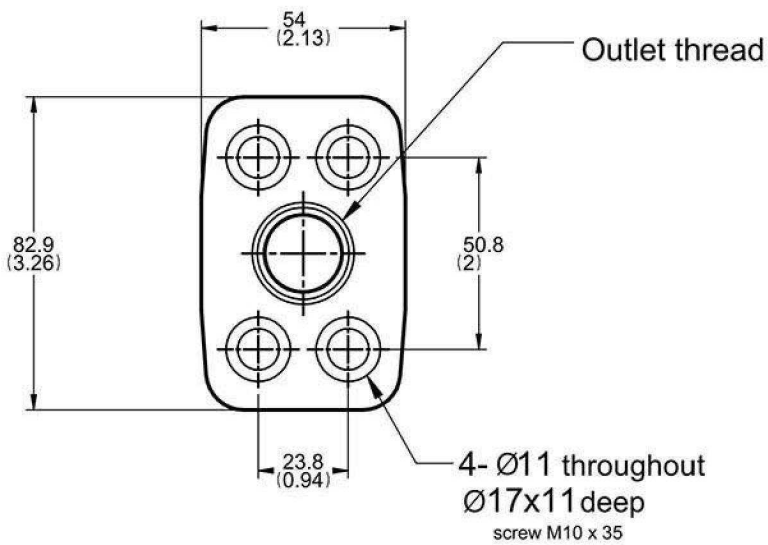

#### Ports

Thread code	3 UNF(SAE)	1 BSPP(G)	2 PT(RC)	7 ISO 6149(M)
Inlet	1 5/8"-12 UN	G 1 1/4"-11	PT 1 1/4"-11	M42*P2.0
Outlet	1 1/16"-12 UN	G 3/4"-14	PT3/4"-14	M27*P2.0

Threads code: 3 & 7 are not standard, not it stock, specially fabricate.

# Dimension

PV032 ~ PV046, PV056, PV065 (Body 2)  
Metric version (motor mounting Ø125)

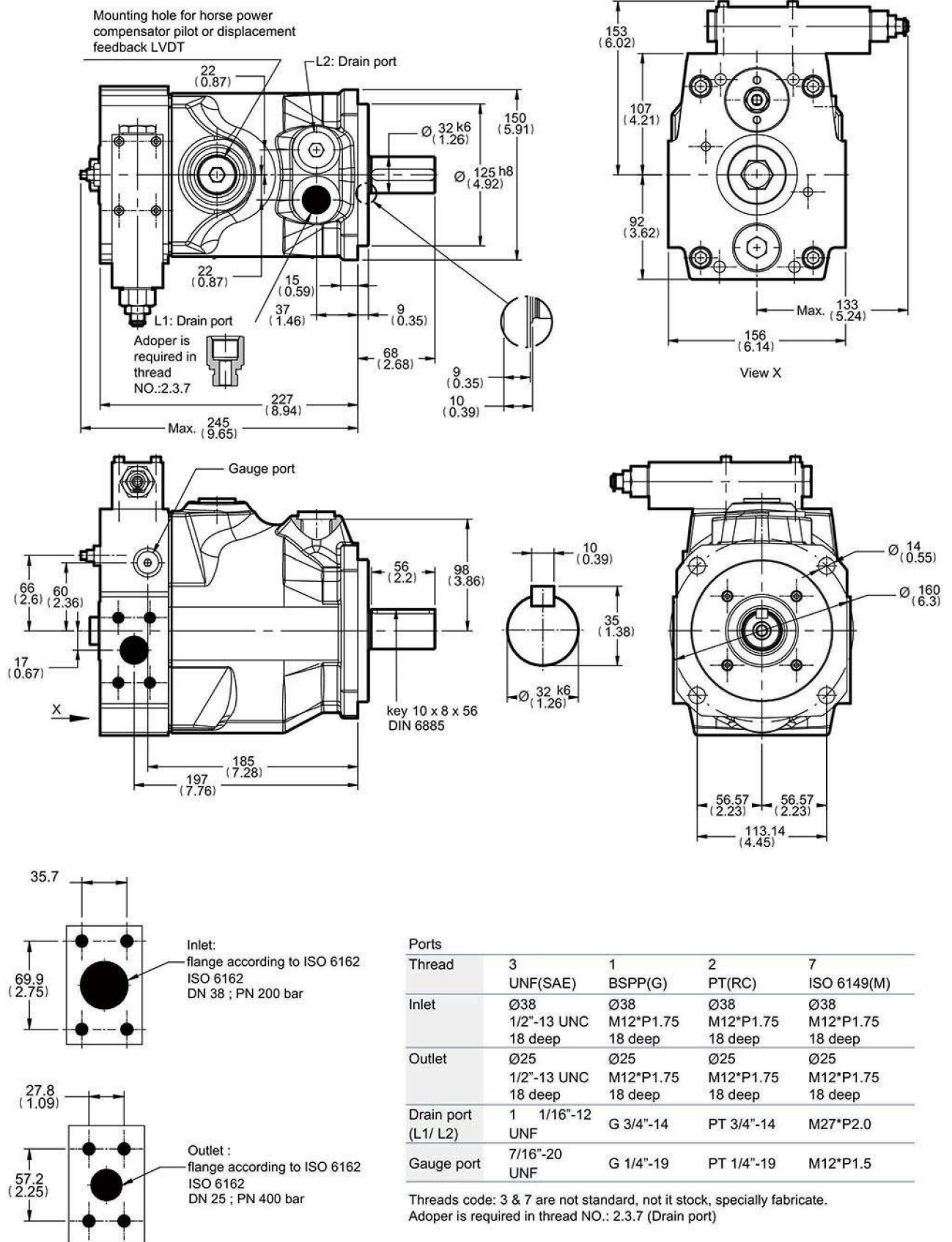

# Dimension

PV032 ~ PV046, PV056, PV065 (Body 2)

Metric version (motor mounting  $\varnothing 125$ )

Shaft type

Mounting code: **M**

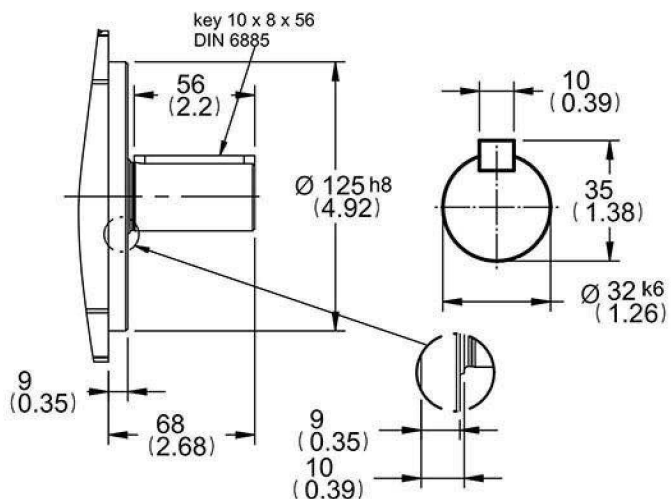

Mounting code: **R**

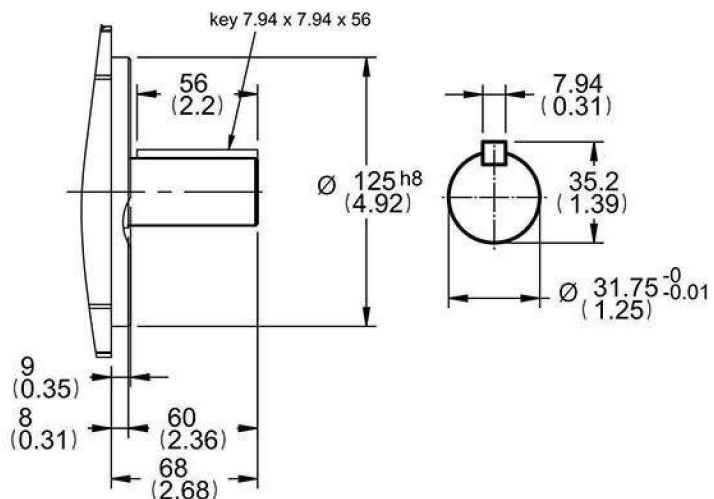

Mounting code: **K**

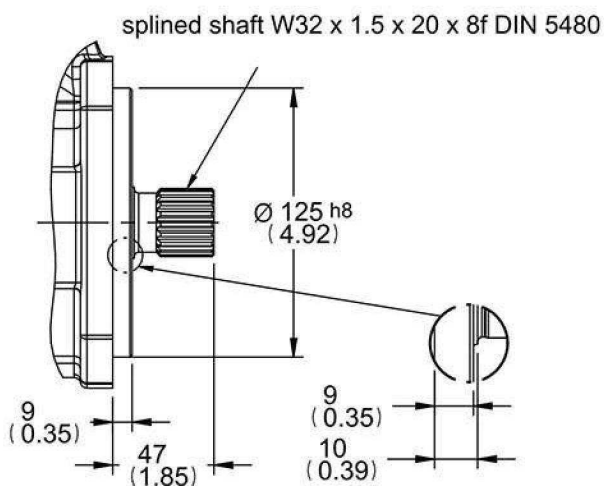

Mounting code: **S**

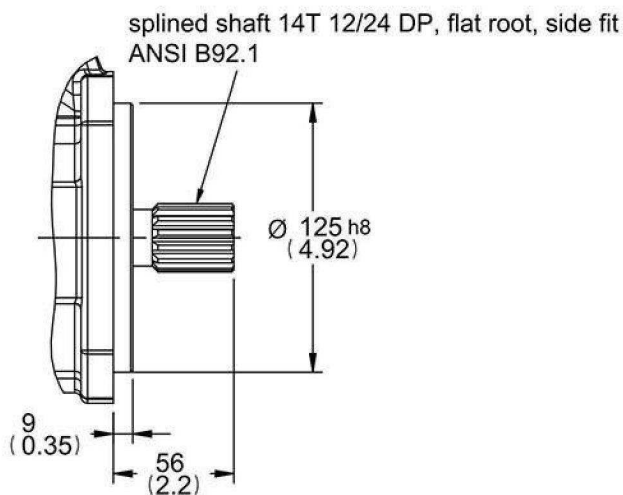

Mounting code: **P**

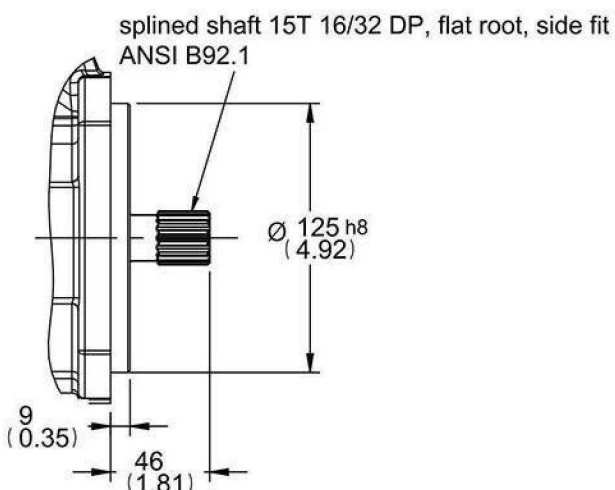



# Dimension

PV032 ~ PV046, PV056, PV065 (Body 2)

SAE version (motor mounting Ø127)

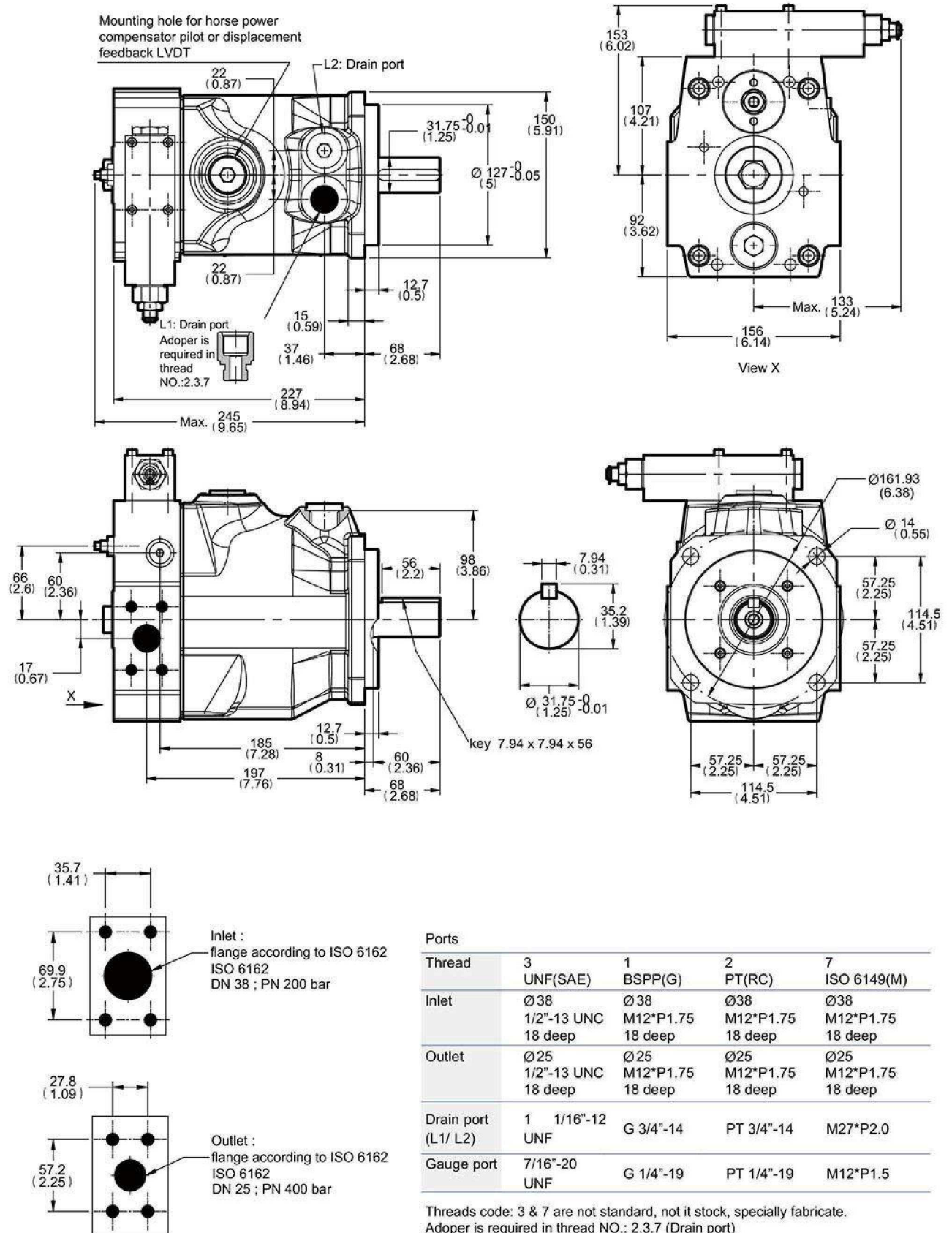

●規格修改，本公司不另行通知  
●Specification is subjected to change without notice.

# Dimension

PV032 ~ PV046, PV056, PV065 (Body 2)

SAE version (motor mounting  $\varnothing 127$ )

Shaft type

Mounting code: **N**

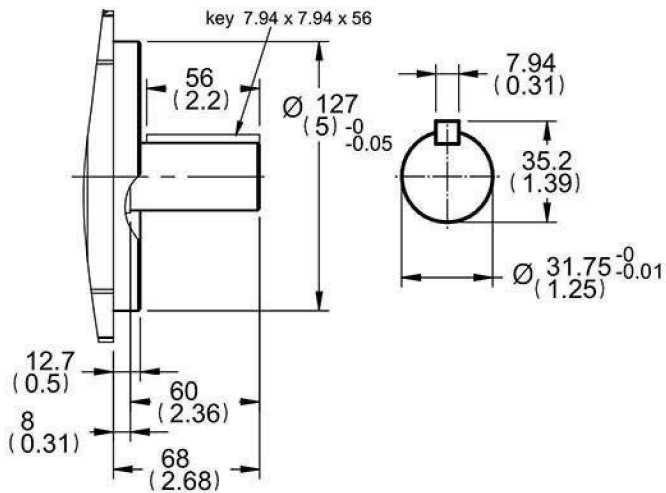

Mounting code: **J**

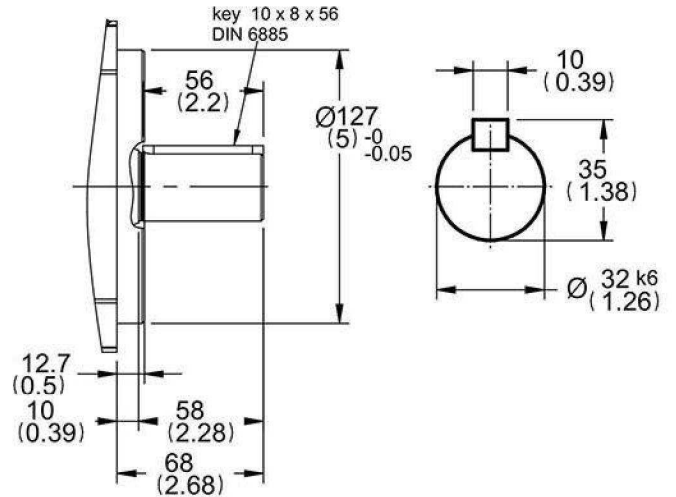

Mounting code: **D**

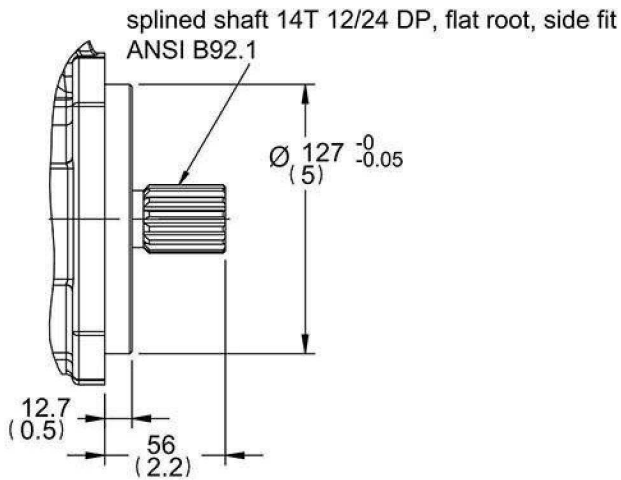

Mounting code: **U**

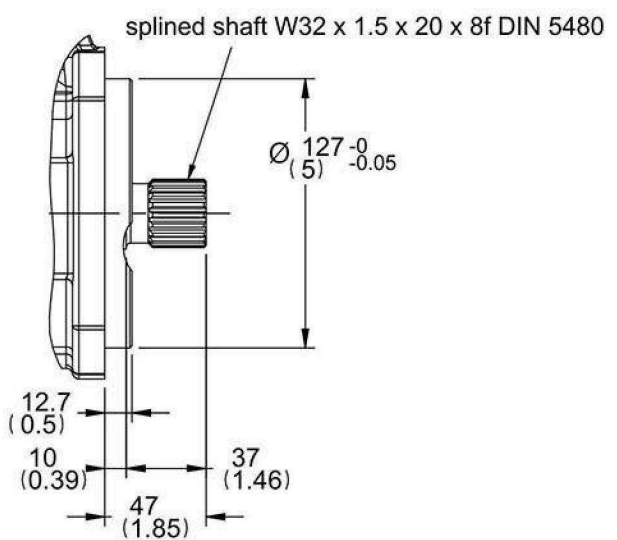

Mounting code: **G**

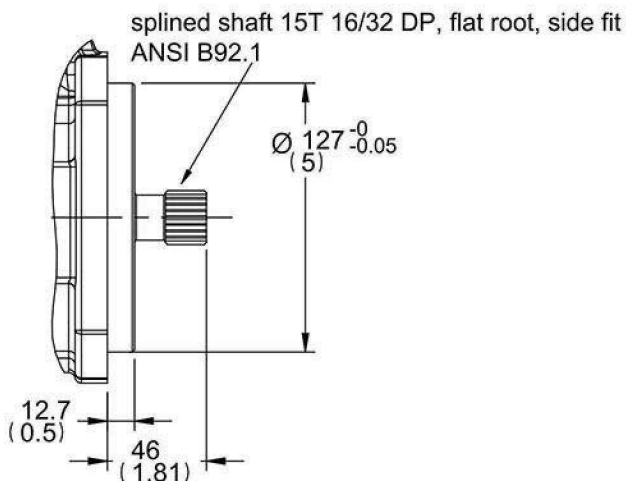

# Dimension

PV032 ~ PV046, PV056, PV065 (Body 2)

Thru drive

Thru drive:  
D, E, F, I, J, K, L

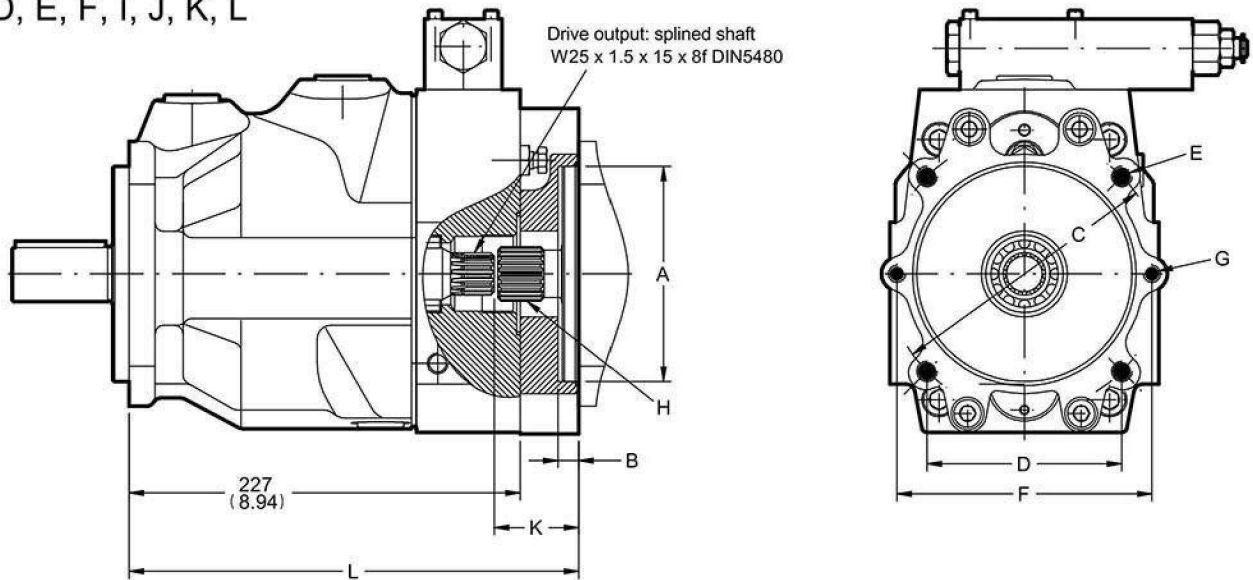

Thru shaft adaptors are available with the following dimensions:

thru code	A	B	C	D	E	F	G	K	L
I	63	8.5	85	-	M8	100	M8	49	261
J	80	8.5	103	-	M8	109	M10	49	261
K	100	10.5	125	-	M10	140	M12	49	261
L	125	12	160	-	M12	n. avail.	n. avail.	49	261
D	82.55	8	-	-	-	106	M10	49	261
E	101.6	11	-	89.8	M10	146	M12	49	261
F	127	13.5	-	114.5	M12	n. avail.	n. avail.	64	276

Thread codes are 3 and 7  
the dimensions E and G are  
UNC-2B threads

threads code: 3 and 7 Not  
standard, not in stock  
require special requests

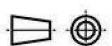

# Dimension

## PV032 ~ PV046, PV056, PV065 (Body 2) Inlet / Outlet Flange

### Inlet Flange

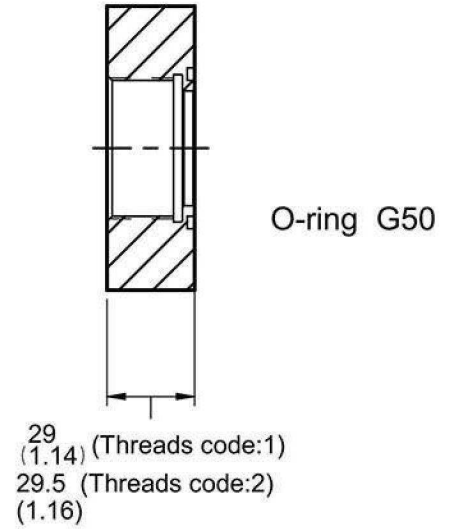
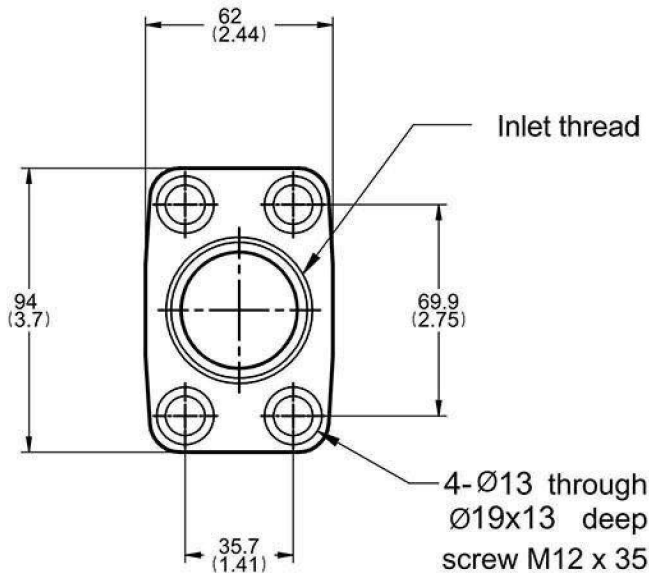

### Outlet Flange

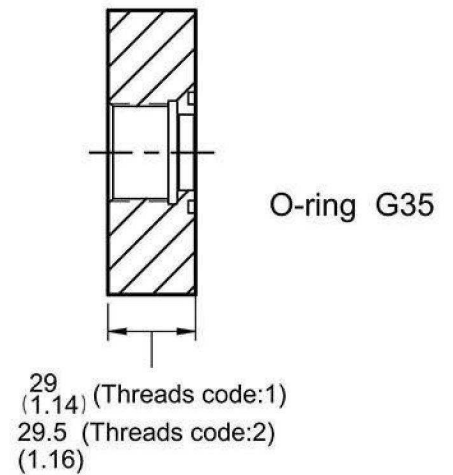
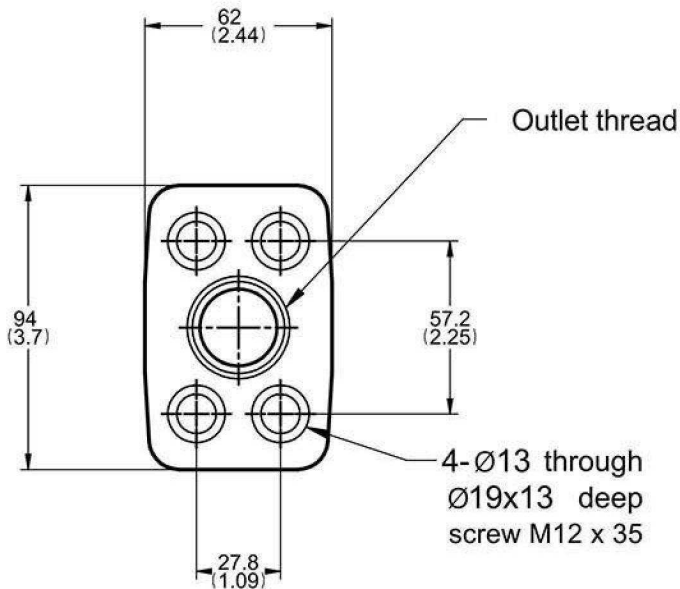

#### Ports

Thread code	3	1	2	7
	UNF(SAE)	BSPP(G)	PT(RC)	ISO 6149(M)
Inlet	1 7/8"-12 UN	G 1 1/2"-11	PT 1 1/2"-11	M48*P2.0
Outlet	1 5/16"-12 UN	G 1"-11	PT 1"-11	M33*P2.0

threads code: 3 & 7 are not standard, not it stock, specially fabricate.

# Dimension

## PV140 ~ PV180, PV210 (Body 4)

### Metric version (motor mounting Ø160)

Mounting hole for horse power compensator pilot or displacement feedback LVDT

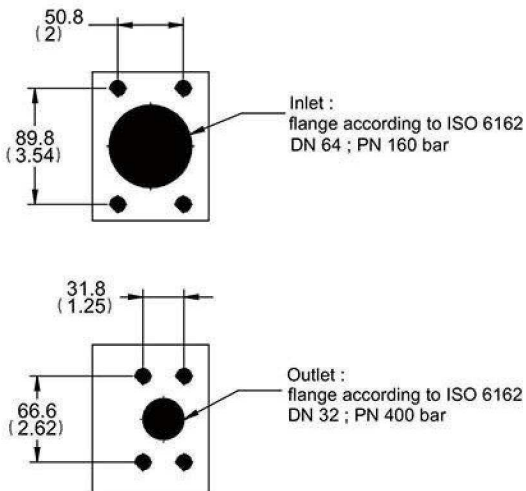
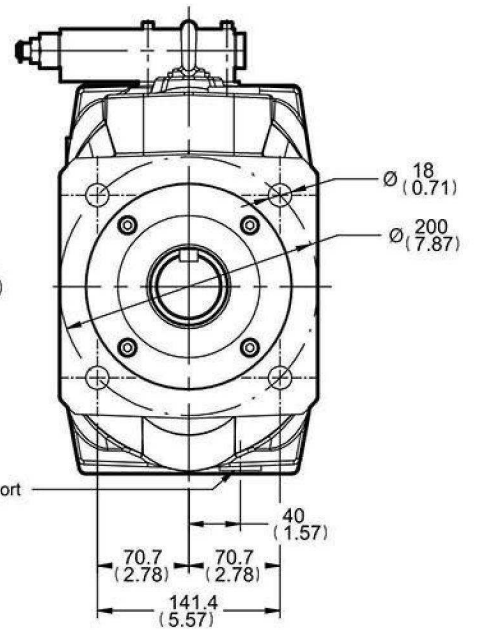
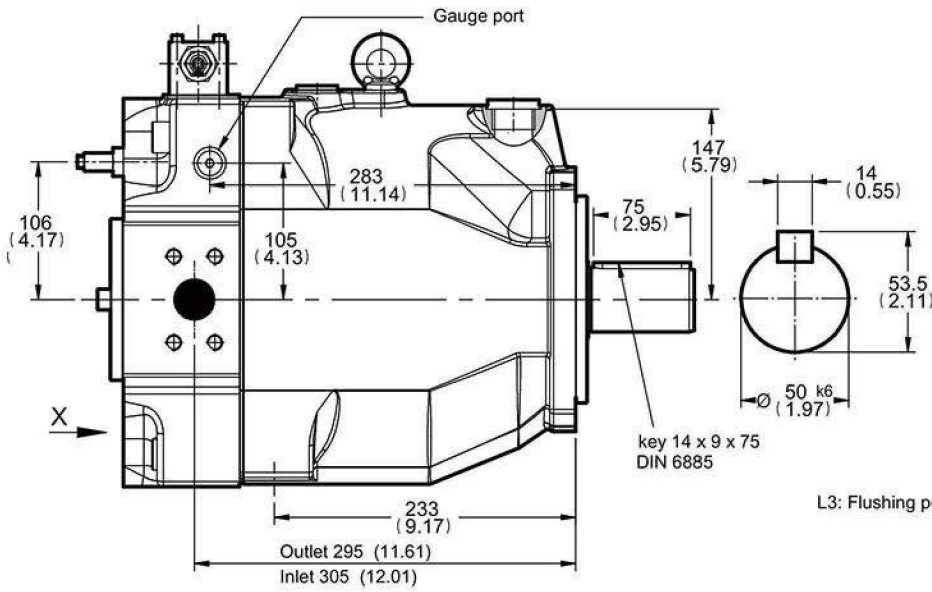
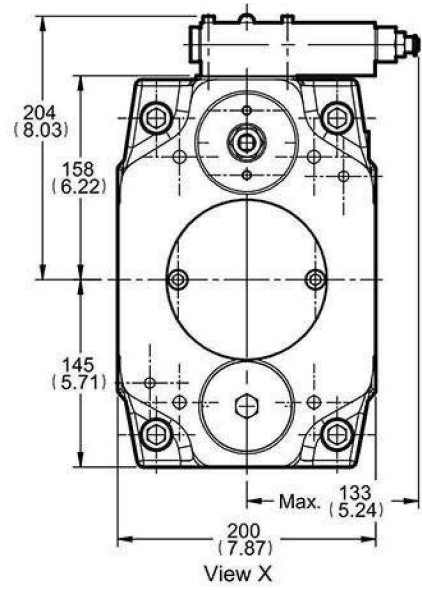
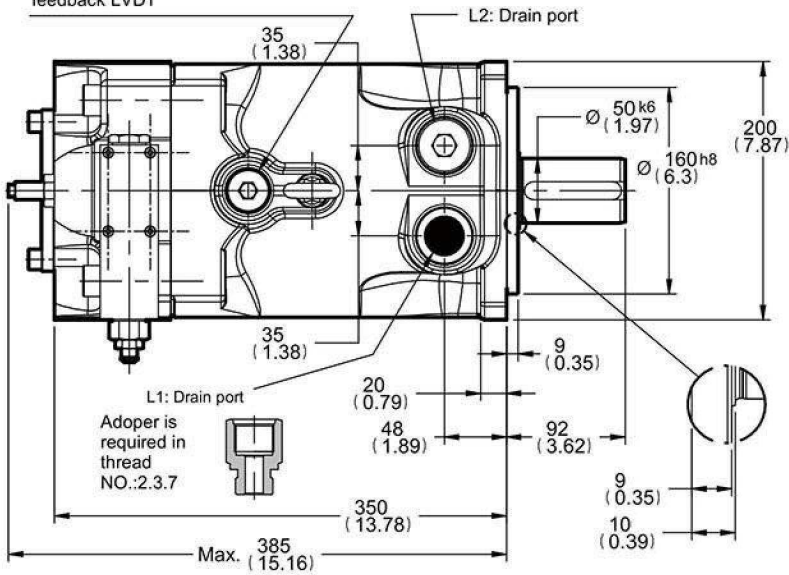

Ports				
Thread	3	1	2	7
	UNF(SAE)	BSPP(G)	PT(RC)	ISO 6149(M)
Inlet	Ø64 1/2"-13 UNC 20 deep	Ø64 M12*P1.75 20 deep	Ø64 M12*P1.75 20 deep	Ø64 M12*P1.75 20 deep
Outlet	Ø32 1/2"-13 UNC 20 deep	Ø32 M12*P1.75 20 deep	Ø32 M12*P1.75 20 deep	Ø32 M12*P1.75 20 deep
Drain port (L1/ L2)	1 5/16"-12 UNF	G 1"-11	PT 1"-11	M33*P2.0
L3	1 1/16"-12 UNF	G 3/4"-14	PT 3/4"-14	M27*P2.0
Gauge port	7/16"-20 UNF	G 1/4"-19	PT 1/4"-19	M12*P1.5

threads code: 3 & 7 are not standard, not it stock, specially fabricate.

Adoper is required in thread NO.:2.3.7 (Drain port)

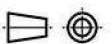

# Dimension

PV140 ~ PV180, PV210 (Body 4)

Metric version (motor mounting  $\varnothing 160$ )

Shaft type

Mounting code: **M**

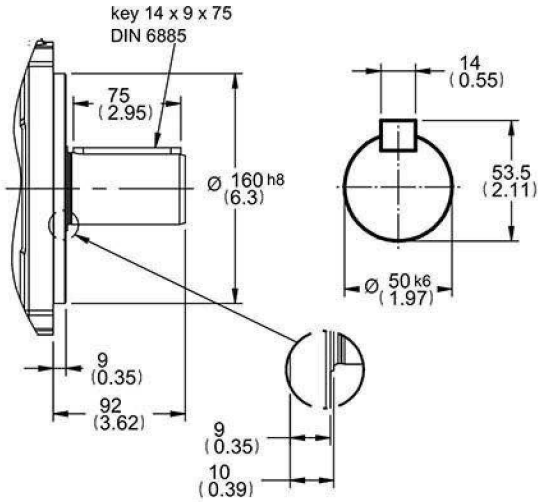

Mounting code: **R**

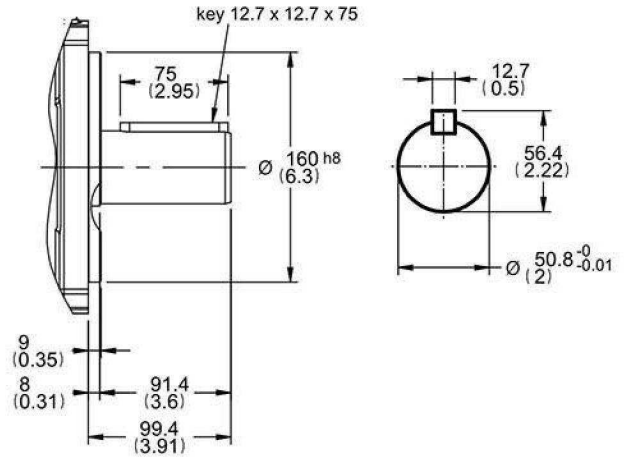

Mounting code: **K**

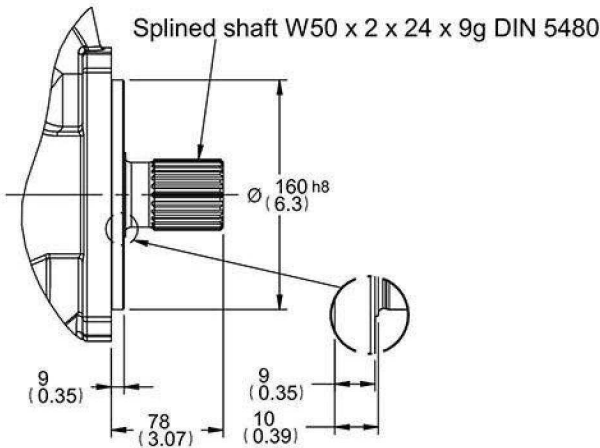

Mounting code: **S**

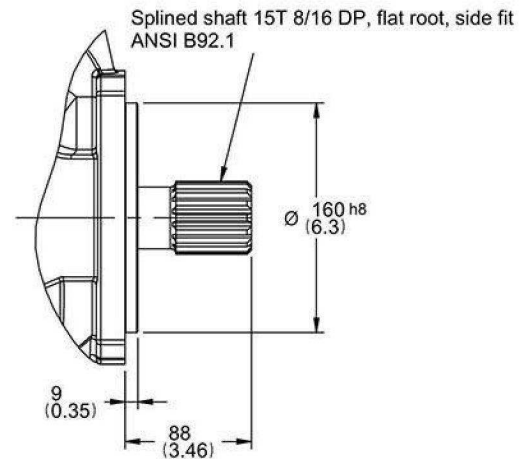

Mounting code: **Q**

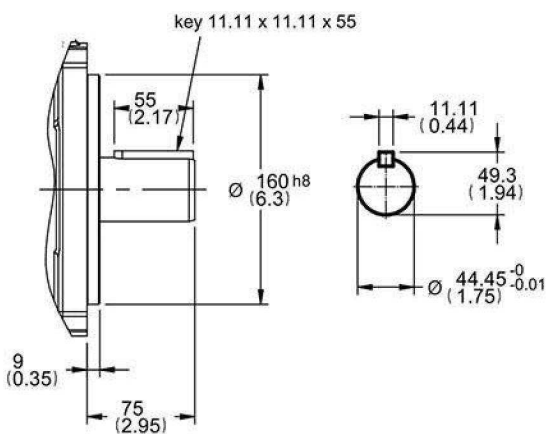

Mounting code: **P**

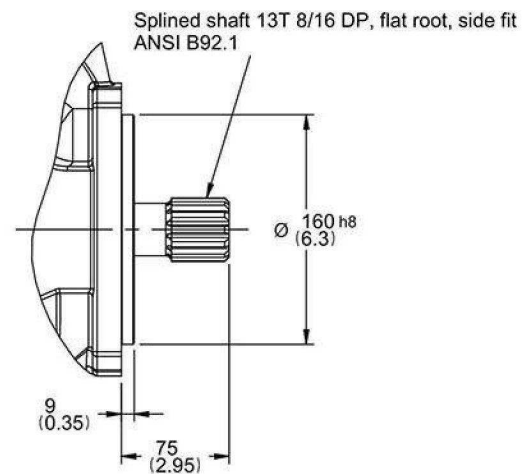

# Dimension

PV140 ~ PV180, PV210 (Body 4)  
SAE version (motor mounting Ø152.4)

Mounting hole for horse power compensator pilot or displacement feedback LVDT

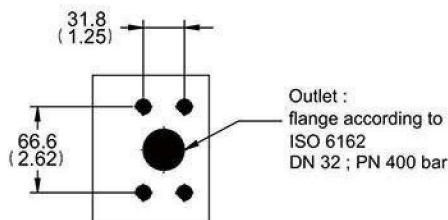
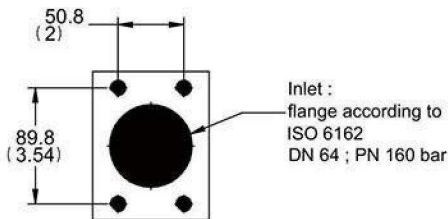
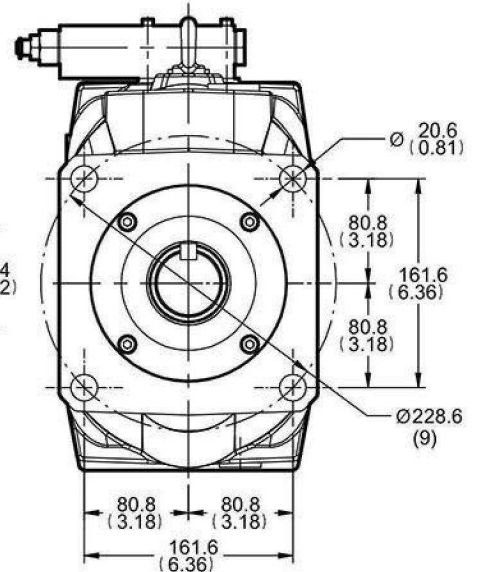
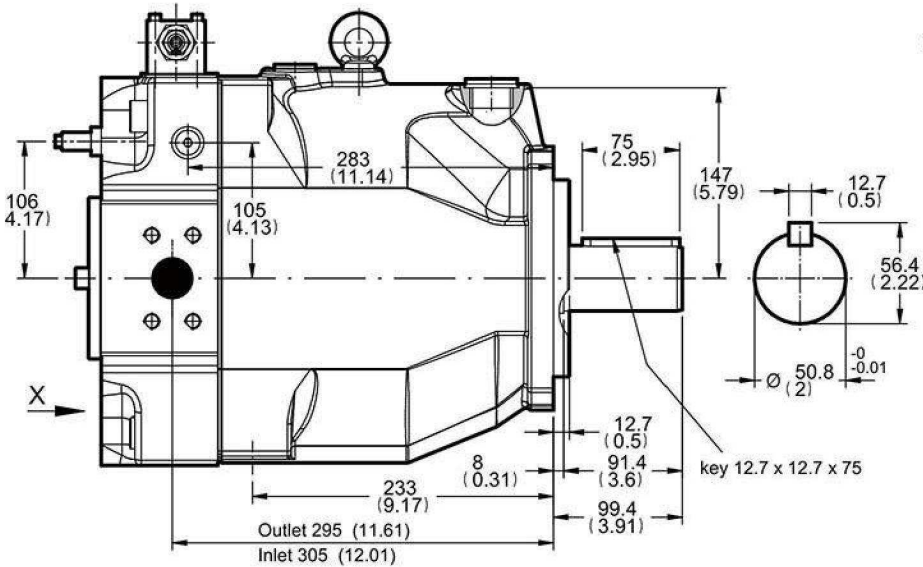
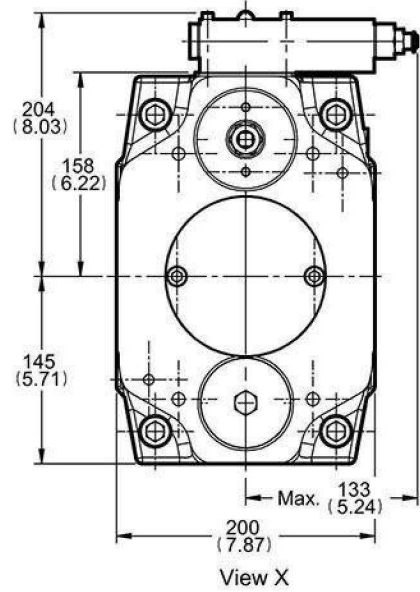
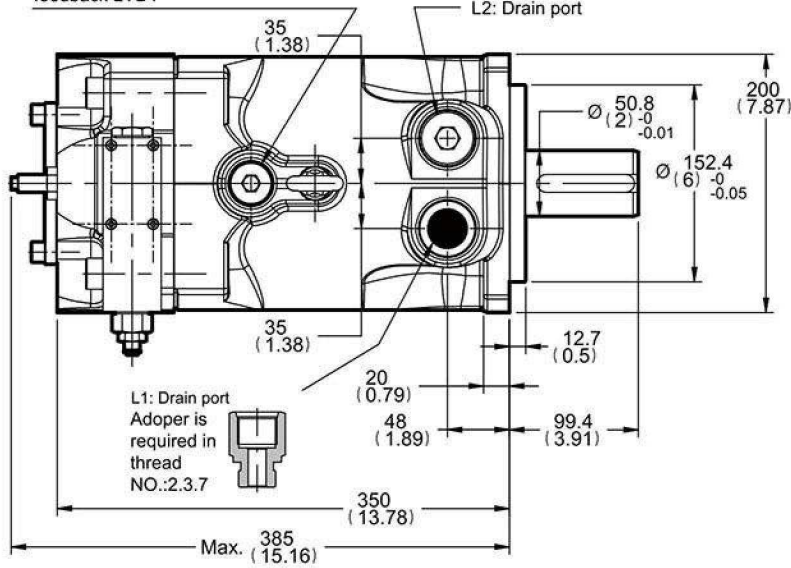

### Ports

Thread	1	2	3	7
	BSPP(G)	PT(RC)	UNF(SAE)	ISO 6149(M)
Inlet	Ø64 M12*P1.75 20 deep	Ø64 M12*P1.75 20 deep	Ø64 1/2"-13 UNC 20 deep	Ø64 M12*P1.75 20 deep
Outlet	Ø32 M12*P1.75 20 deep	Ø32 M12*P1.75 20 deep	Ø32 1/2"-13 UNC 20 deep	Ø32 M12*P1.75 20 deep
Drain port (L1/ L2)	G 1"-11	PT 1"-11	1 5/16"-12 UNF	M33*P2.0
L3	G 3/4"-14	PT 3/4"-14	1 1/16"-12 UNF	M27*P2.0
Gauge port	G 1/4"-19	PT 1/4"-19	7/16"-20 UNF	M12*P1.5

threads code: 3 & 7 are not standard, not it stock, specially fabricate.  
Adoper is required in thread NO.:2.3.7 (Drain port)



# Dimension

PV140 ~ PV180, PV210 (Body 4)

SAE version(motor mounting  $\text{Ø}152.4$ )

Shaft type

Mounting code: **N**

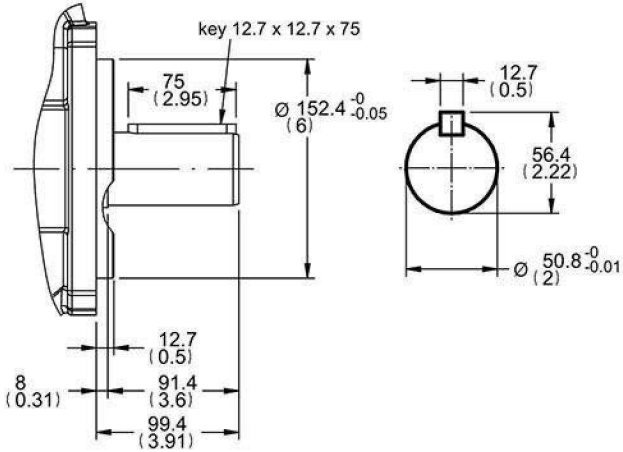

Mounting code: **J**

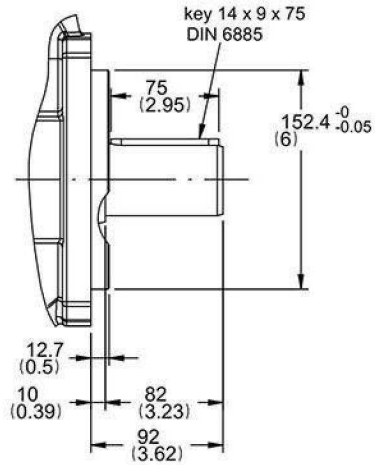

Mounting code: **D**

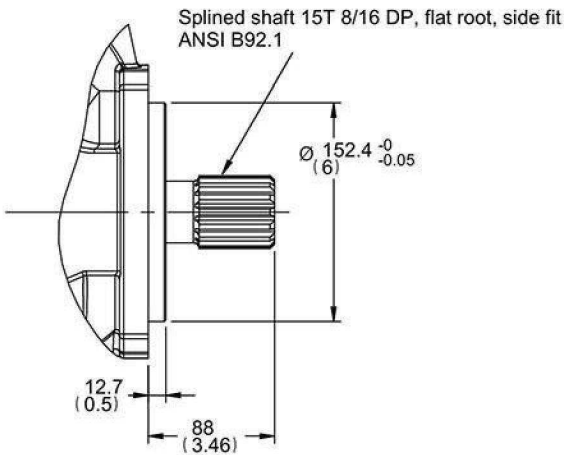

Mounting code: **U**

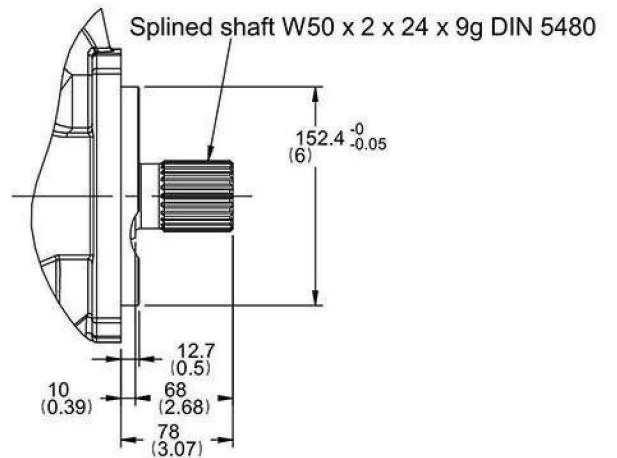

Mounting code: **G**

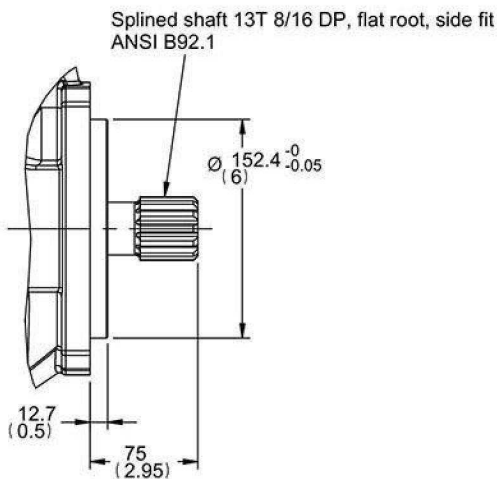

Mounting code: **F**

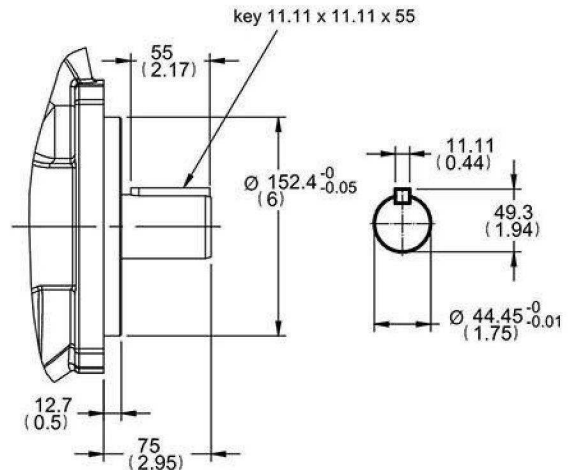



# Dimension

PV140 ~ PV180, PV210 (Body 4)

Thru drive

Thru drive:

D, E, F, G, J, K, L, M

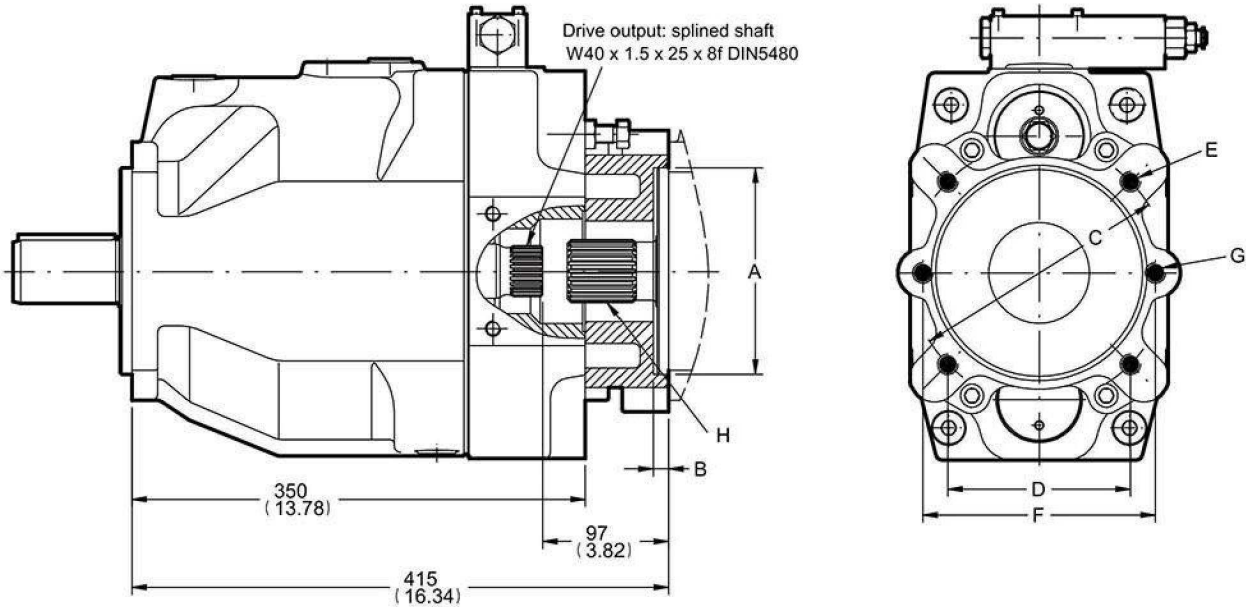

Thru shaft adaptors are available with the following dimensions:

thru code	A	B	C	D	E	F	G
J	80	10	103	-	M8	109	M10
K	100	12	125	-	M10	140	M12
L	125	12	160	-	M12	180	M16
M	160	12	200	-	M16	n. avail.	n. avail.
D	82.55	10	-	-	-	106	M10
E	101.6	12	-	89.8	M10	146	M12
F	127	14	-	114.5	M12	181	M16
G	152.4	14	-	161.6	M16	n. avail.	n. avail.

Thread codes are 3 and 7  
the dimensions E and G are  
UNC-2B threads

threads code: 3 and 7 Not  
standard, not in stock  
require special requests.

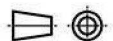

# Dimension

## PV140 ~ PV180, PV210 (Body 4) Inlet / Outlet Flange

### Inlet Flange

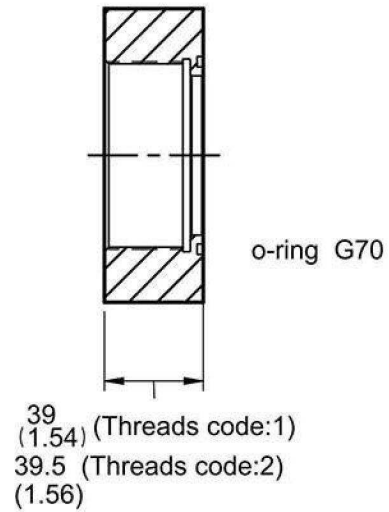
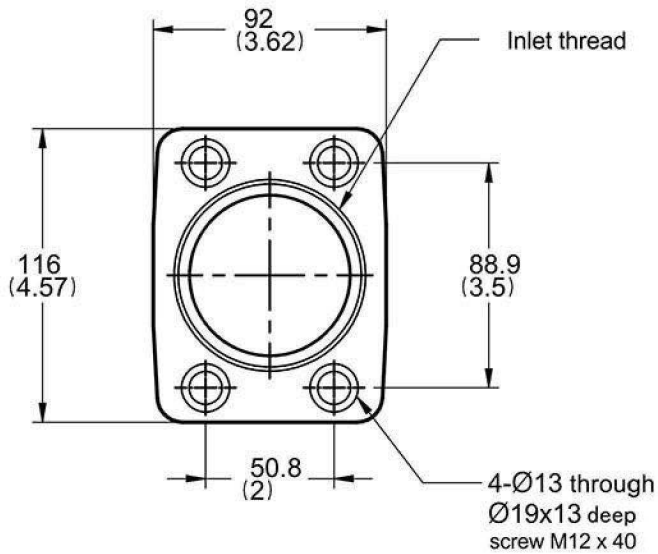

### Outlet Flange

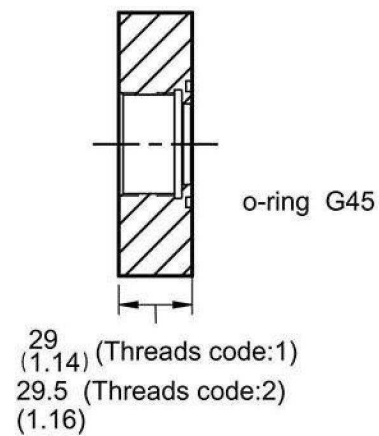
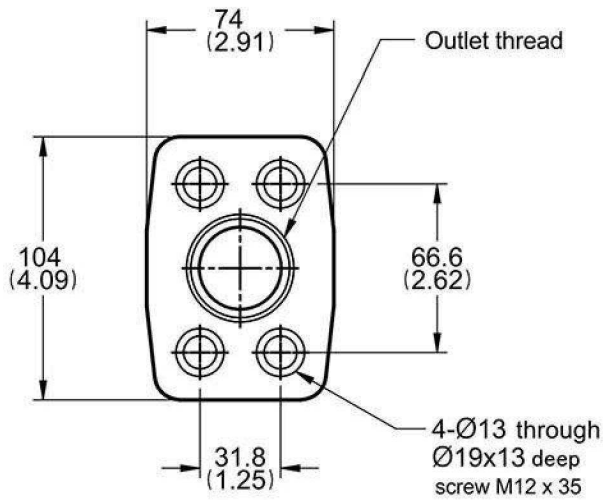

### Ports

Thread code	3	1	2	7
	UNF(SAE)	BSPP(G)	PT(RC)	ISO 6149(M)
Inlet	Welding	G 2 1/2"-11	PT 2 1/2"-11	Welding
Outlet	1 5/8"-12 UN	G 1 1/4"-11	PT 1 1/4"-11	M42*P2.0

threads code: 3 & 7 are not standard, not it stock, specially fabricate.

# Dimension

## PV270 (Body 5)

Metric version (motor mounting  $\varnothing 200$ )

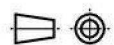
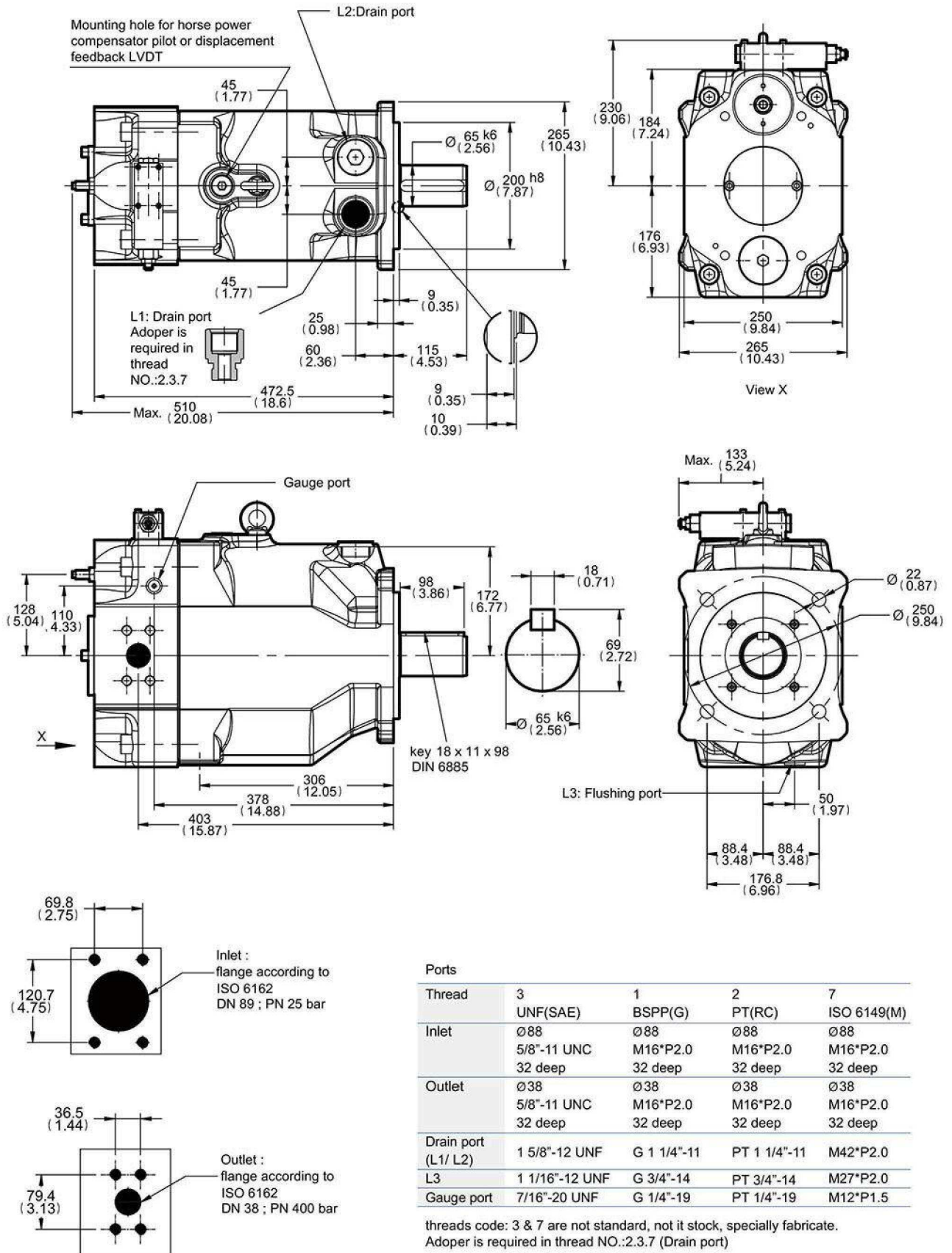

# Dimension

## PV270 (Body 5)

Metric version (motor mounting  $\text{Ø}200$ )

Shaft type

Mounting code: **M**

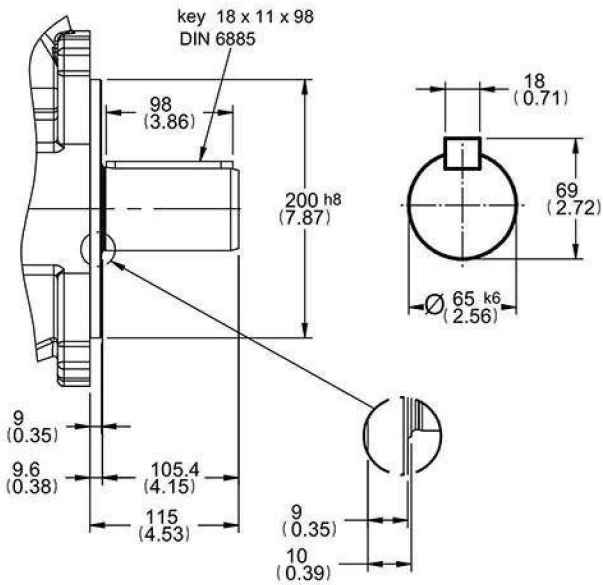

Mounting code: **R**

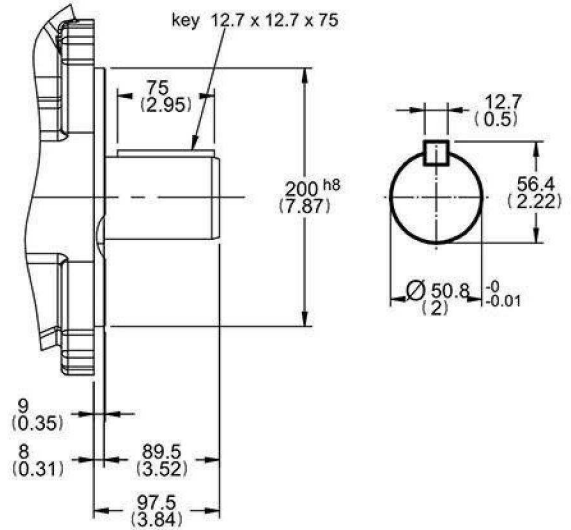

Mounting code: **K**

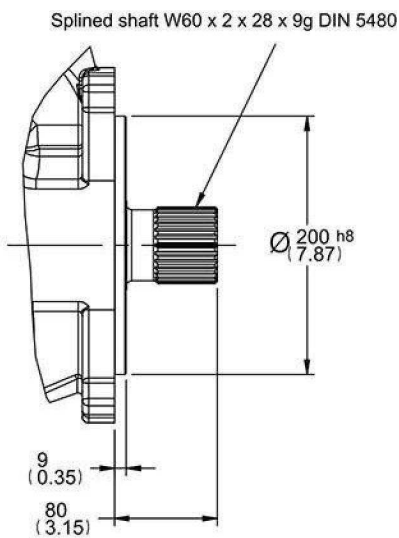

Mounting code: **S**

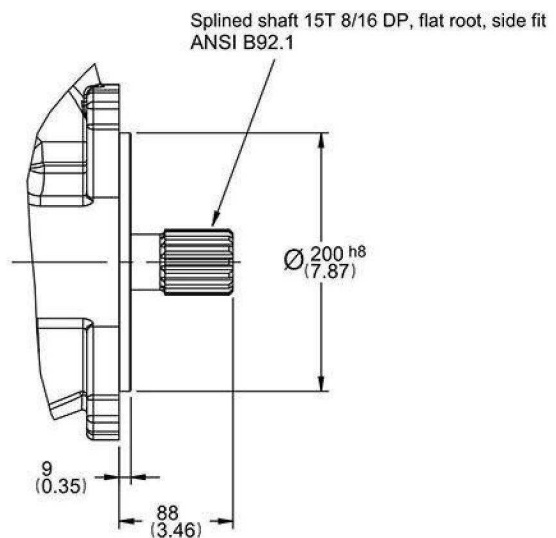

# Dimension

## PV270 (Body5)

SAE version (motor mounting  $\varnothing 165.1$ )

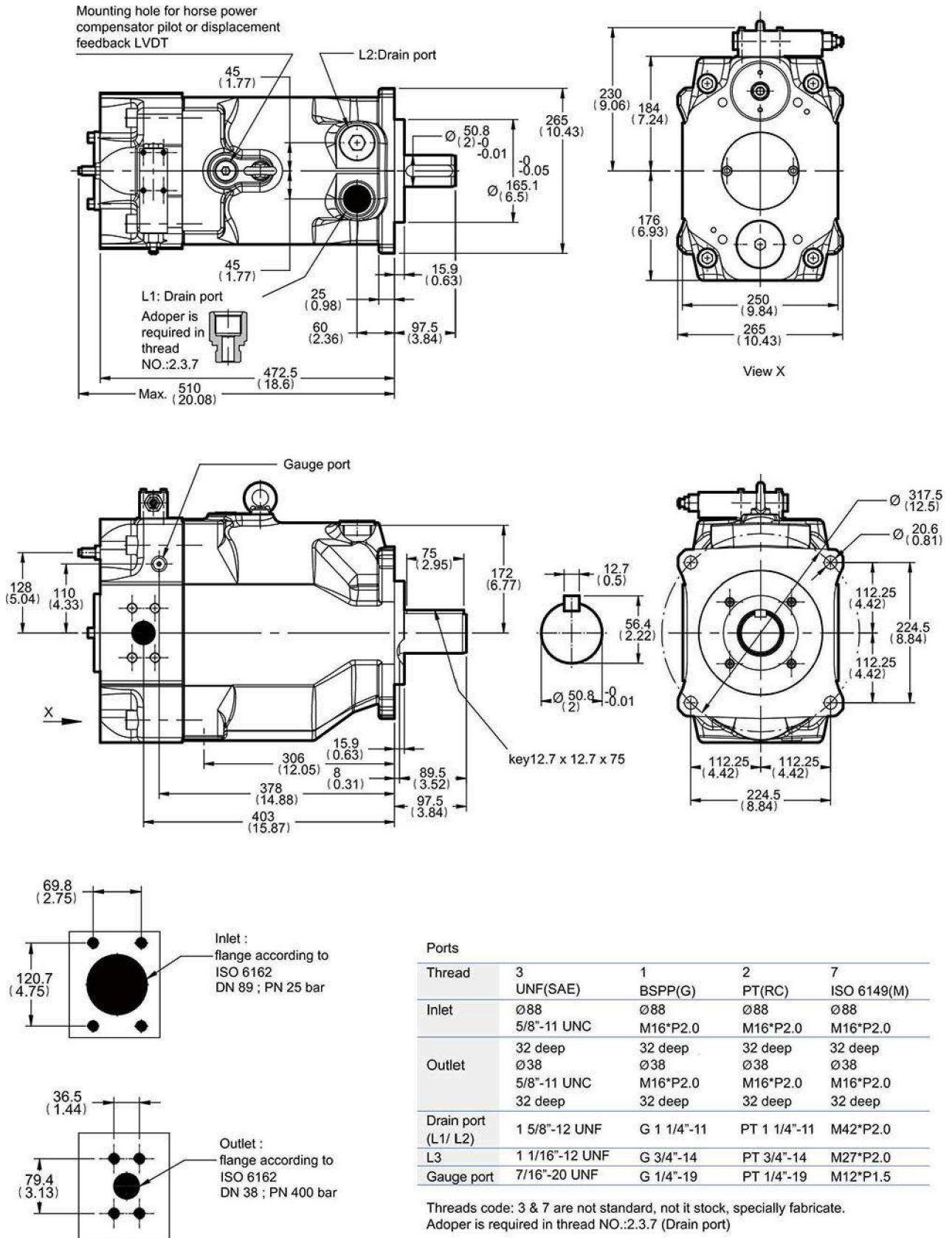

# Dimension

## PV270 (Body 5)

SAE version(motor mounting  $\varnothing 165.1$ )

Shaft type

Mounting code: **N**

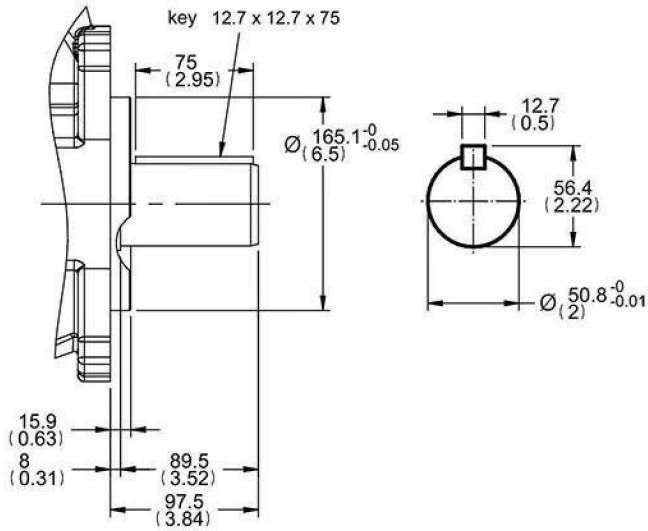

Mounting code: **J**

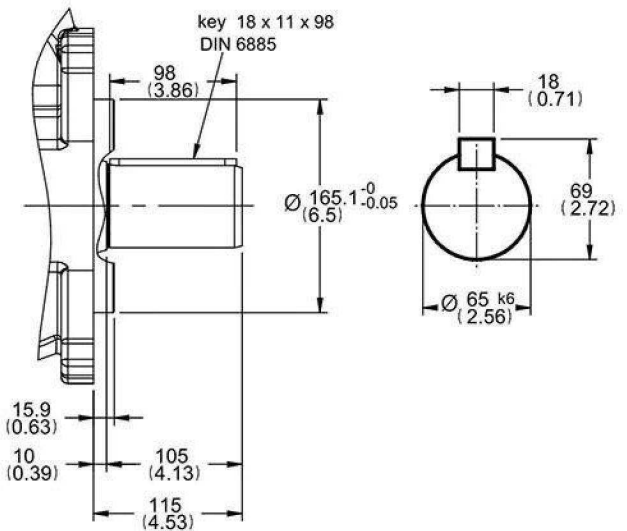

Mounting code: **D**

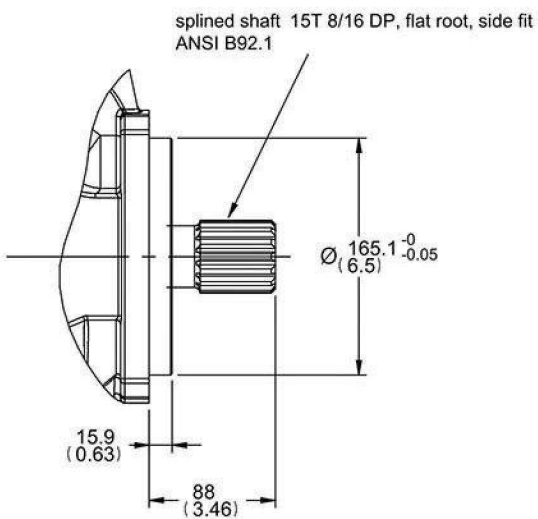

Mounting code: **U**

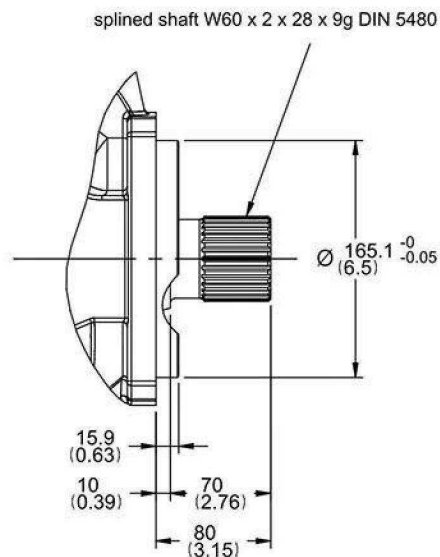

# Dimension

## PV270 (Body 5)

Thru drive

Thru drive:

D, E, F, G, H, J, K, L, M, N

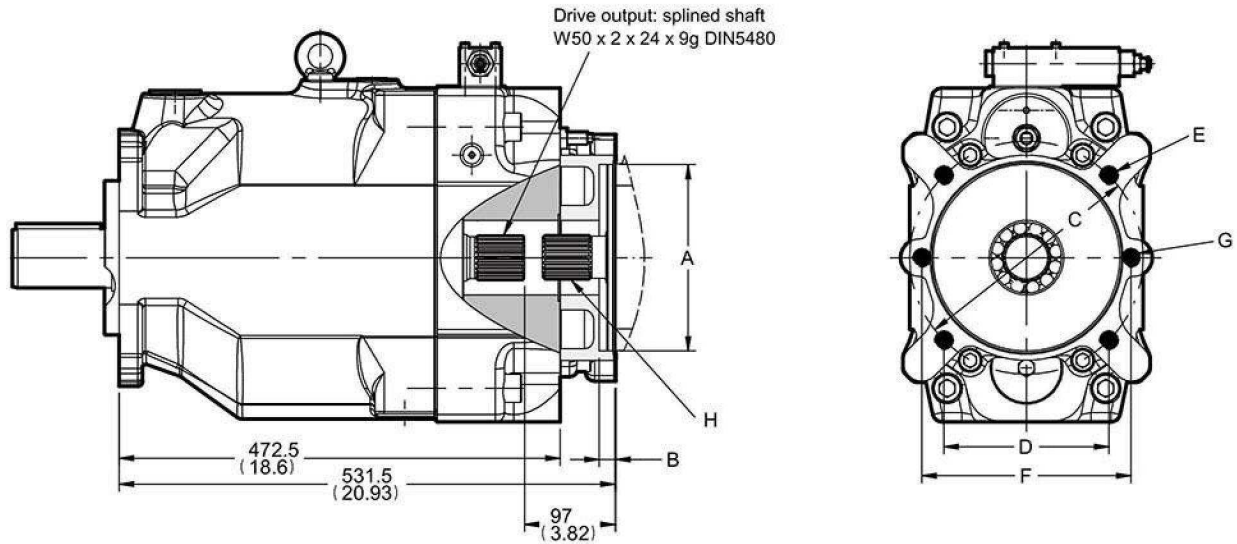

Thru shaft adaptors are available with the following dimensions:

thru code	A	B	C	D	E	F	G
J	80	8.5	103	-	M8	109	M10
K	100	10.5	125	-	M10	140	M12
L	125	10.5	160	-	M12	180	M16
M	160	13.5	200	-	M16	224	M20
N	200	13.5	250	-	M20	n. avail.	n. avail.
D	82.55	8	-	-	-	106	M10
E	101.6	11	-	89.8	M10	146	M12
F	127	13.5	-	114.5	M12	181	M16
G	152.4	13.5	-	161.6	M16	229	M20
H	165.1	17	-	224.5	M20	n. avail.	n. avail.

Thread codes are 3 and 7 the dimensions E and G are UNC-2B threads

threads code: 3 and 7 Not standard, not in stock require special requests.



# Dimension

## PV270 (Body 5) Inlet / outlet Flange

Thru drive

### Inlet Flange

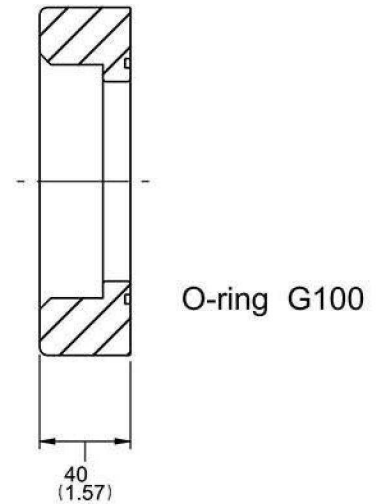
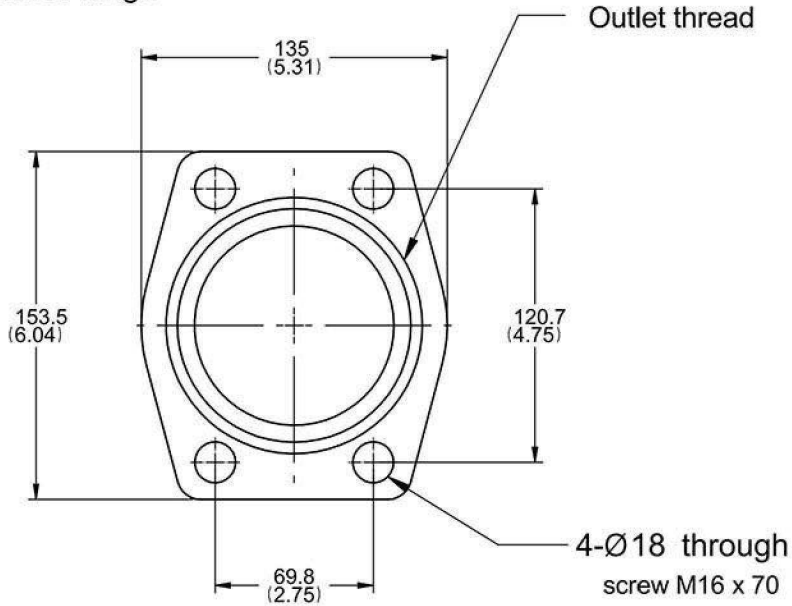

### Outlet Flange

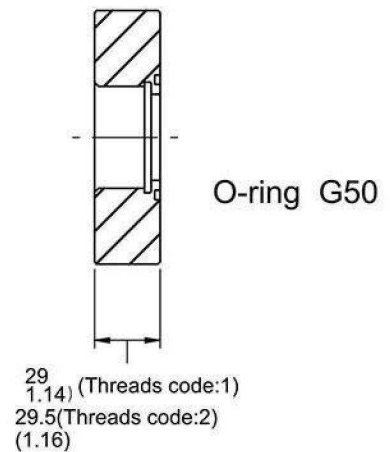
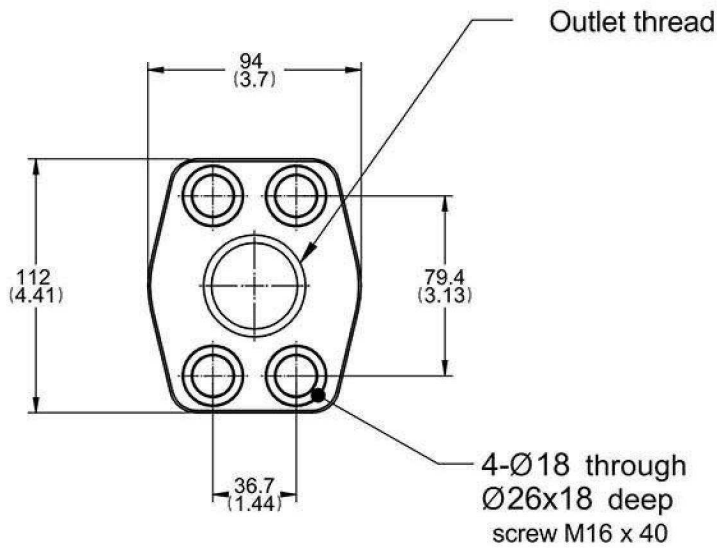

#### Ports

Thread code	3	1	2	7
	UNF(SAE)	BSPP(G)	PT(RC)	ISO 6149(M)
Inlet	welding 3 1/2"			
Outlet	1 7/8"-12 UN	G 1 1/2"-11	PT 1 1/2"-11	M48*P2.0

Threads code: 3 & 7 are not standard, not it stock, specially fabricate.



# Pump combination

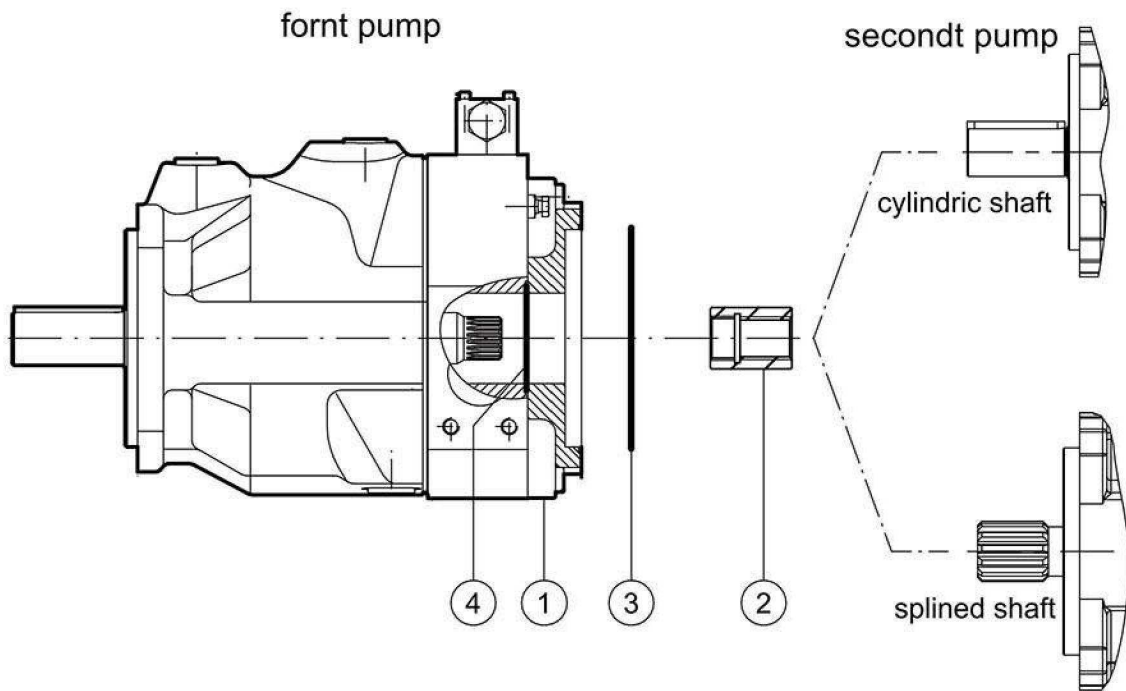

NO.	Name
1	adapter
2	coupling
3	front pump o-ring
4	second pump o-ring

Order code refers to next page

# Pump combination

## ② Coupling Order no.

Second pump		Fornt pump Size				
Second pump shaft	Model	Body 1 (PV016~023, PV028)	Body 2 (PV032~046, 056,065 )	Body 3 (PV063~092, 110,125)	Body 4 (PV140~180, 210)	Body 5 (PV270)
SAE splined shaft						
9T 16/32 DP		4A505032	4A505037	4A505051	4A505058	4A505069
11T 16/32 DP		--	--	--	--	--
13T 16/32 DP		4A505033	4A505034	4A505047	4A505059	4A505070
15T 16/32 DP	(PV016~023,PV028) (PV032~046,056,065)	--	4A505040	4A505120	4A505060	4A505071
14T 12/24 DP	(PV032~046,056,065)	--	4A505036	4A505052	4A505061	4A505072
17T 12/24 DP		--	--	--	--	--
13T 8/16 DP	(PV063~092, 110, 125) (PV140~180,210)	--	--	--	4A505062	4A505073
15T 8/16 DP	(PV140~180,210) (PV270)	--	--	--	4A505063	4A505074
splined shaft DIN 5480						
15T W25x1.5x15	(PV016~023,PV028)	4A505031	4A505038	4A505049	4A505057	4A505068
20T W32x1.5x20	(PV032~046,056,065)	--	4A505039	4A505048	4A505056	4A505067
25T W40x1.5x25	(PV063~092,110,125)	--	--	4A505050	4A505055	4A505066
24T W50x2.0x24	(PV140~180,210)	--	--	--	4A505054	4A505065
28T W60x2.0x28	(PV270)	--	--	--	--	4A505075
cylindric shaft						
ø19.05*4.76		--	--	--	--	--
ø22.22*4.76		--	4A505042	4A505043	4A505053	4A505064
ø22.22*6.35		--	4A505042	4A505043	4A505053	4A505064
ø25.4*6.35	(PV016~023,PV028)	--	4A505041	--	--	--
ø31.75*7.94	(PV032~046,056,065)	--	--	--	--	--
ø44.45*11.11	(PV063~092,110,125) (PV140~180,210)	--	--	--	--	--
ø50.8*12.7	(PV140~180,210) (PV270)	--	--	--	--	--
cylindric shaft						
ø25*8	(PV016~023,028)	--	4A505035	--	--	--
ø32*10	(PV032~046,056,065)	--	--	--	--	--
ø40*12	(PV063~092,110,125)	--	--	--	--	--
ø50*14	(PV140~180,210)	--	--	--	--	--
ø65*18	(PV270)	--	--	--	--	--

# Pump combination

order no.

Fornt pump	Thru drive code	①	③	④
		Adapter	Fornt pump o-ring	Second pump o-ring
Body 1 (PV016~023,028)	I φ 63	4A504012	3AAA1BA134	3AAC1AA065
	J φ 80	4A504013	3AAA1BA134	3AAC1AA085
	K φ 100	4A504014	3AAA1BA134	3AAC1AA105
	C φ 50.8	4A504015	3AAA1BA134	3AAC1AA055
	D φ 82.55	4A504016	3AAA1BA134	3AAC1AA085
	E φ 101.6	4A504017	3AAA1BA134	3AAC1AA105
Body 2 (PV032~046,056,065)	I φ 63 (261L)	--	3AAA1BA146	--
	J φ 80 (261L)	--	3AAA1BA146	3AAD1AA080
	K φ 100 (261L)	4A504023	3AAA1BA146	3AAD1AA100
	L φ 125 (261L)	4A504024	3AAA1BA146	3AAD1AA125
	D φ 82.55 (261L)	4A504020	3AAA1BA146	3AAD1AA085
	E φ 101.6 (261L)	4A504021	3AAA1BA146	3AAD1AA100
	S φ 101.6 (276L)	4A504018	3AAA1BA146	3AAD1AA100
F φ 127 (276L)	4A504019	3AAA1BA146	3AAD1AA130	
Body 3 (PV063~092,110,125)	I φ 63	--	3AAA1BA146	--
	J φ 80	4A504030	3AAA1BA146	3AAD1AA080
	K φ 100	4A504031	3AAA1BA146	3AAD1AA100
	L φ 125	4A504032	3AAA1BA146	3AAD1AA125
	M φ 160	4A504033	3AAA1BA146	3AAF1AA316
	D φ 82.55	4A504025	3AAA1BA146	3AAD1AA085
	E φ 101.6	4A504026	3AAA1BA146	3AAD1AA100
	F φ 127	4A504027	3AAA1BA146	3AAD1AA130
	G φ 152.4	4A504028	3AAA1BA146	3AAA1AA163
Body 4 (PV140~180,210)	J φ 80	4A504039	3AAA1BA153	3AAD1AA080
	K φ 100	4A504040	3AAA1BA153	3AAD1AA100
	L φ 125	4A504041	3AAA1BA153	3AAD1AA125
	M φ 160	4A504042	3AAA1BA153	3AAF1AA316
	D φ 82.55	4A504035	3AAA1BA153	3AAD1AA085
	E φ 101.6	4A504036	3AAA1BA153	3AAD1AA100
	F φ 127	4A504037	3AAA1BA153	3AAD1AA130
	G φ 152.4	4A504038	3AAA1BA153	3AAA1AA163
Body 5 (PV270)	J φ 80	4A504049	3AAA1BA153	3AAD1AA080
	K φ 100	4A504050	3AAA1BA153	3AAD1AA100
	L φ 125	4A504051	3AAA1BA153	3AAD1AA125
	M φ 160	4A504052	3AAA1BA153	3AAF1AA316
	N φ 200	4A504053	3AAA1BA153	3AAF1AA320
	D φ 82.55	4A504044	3AAA1BA153	3AAD1AA085

# Dimensions

## Double pump dimensions

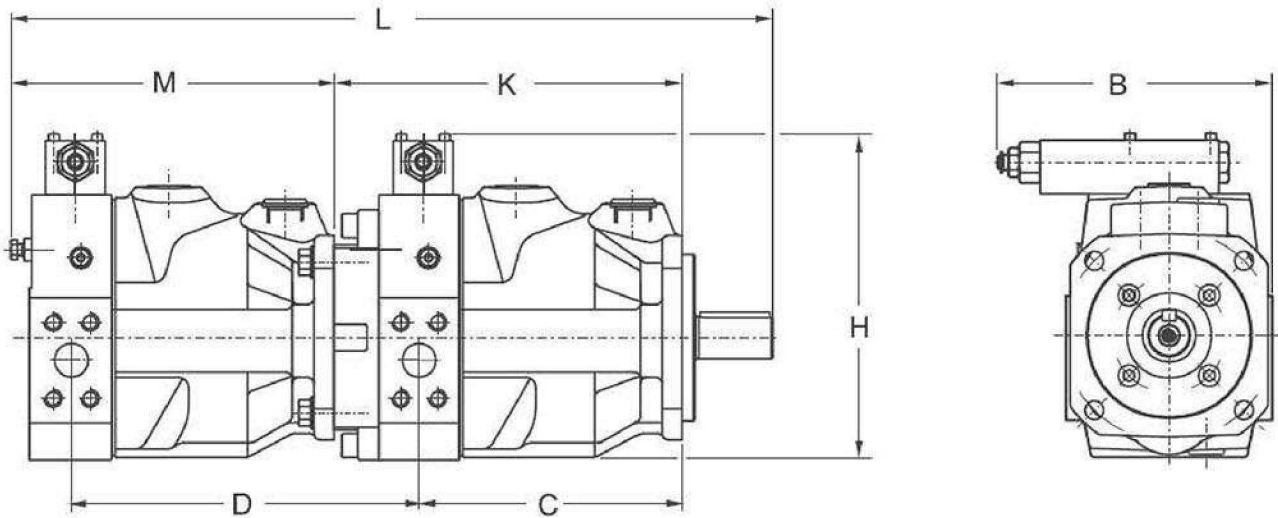

Main pump	Second pump	Interface main pump	L	B	C	D	H	K	M
PV016,020,023,028	PV016,020,023,028	100 B4 HW	489	196	170.5	225	220	225	212
PV032,040,046, 056,065	PV016,020,023,028	125 B4 HW	541	208	197	235.5	245	261	212
	PV032,040,046,056,065		574	208	197	261	245	261	245
PV063,080,092 110,125	PV016,020,023,028	160 B4 HW	630	232	252	244.5	299	326	212
	PV032,040,046,056,065		663	232	252	271	299	326	245
	PV063,080,092,110,125		724	232	252	326	299	326	306
PV140,180,210	PV016,020,023,028	160 B4 HW	719	230	305	208.5	349	415	212
	PV032,040,046,056,065		752	230	305	307	349	415	245
	PV063,080,092,110,125		813	230	305	362	349	415	306
	PV140,180,210		878	230	305	415	349	415	385
PV270	PV016,020,023,028	200 B4 HW	860	255	403	299	406	531.5	212
	PV032,040,046,056,065		893	255	403	325.5	406	531.5	245
	PV063,080,092,110,125		954	255	403	380.5	406	531.5	306
	PV140,180,210		1033	255	403	433.5	406	531.5	385
	PV270		1134	255	403	531.5	406	531.5	510

# PV Axial Piston Pump

## Thru drive, shaft load limitations

The max. Transferable torque in Nm for the different shafts options are:

Shaft code	PV016-023 PV028	PV032-046 PV056&065	PV063-125	PV032-046 PV210	PV270
N	300	550	1320	2000	2000
D	300	610	1218	2680	2680
F	-	-	-	1320	-
G	-	-	-	1640	-
M	300	570	1150	1900	2850
K	405	675	1400	2650	3980

### Important notice

The max. allowable torque of the individual shaft must not be exceeded.

For 2-pump combinations, there is no problem because PV series offers 100%thru torque.

For 3-pump combinations (or more), the limit torque will be reached or exceeded.

Therefore, it is necessary to calculate the torque factor and compare with the allowed torque limit factor in the table.

Requirement: calculated torque factor  
< torque factor

To make the necessary calculations easier and more user friendly it is not required to calculate actual torque requirements in Nm and compare them with the shaft limitations. The table on the right shows limit factors that include material specification, safety factors and conversion factors.

The total torque factor is represented by the sum of the individual torque factors of all pumps in the complete pump combination.

The torque factor of each individual pump is calculated by multiplying the max. operating pressure  $p$  of the pump (in bar) with the max. displacement  $V_g$  of the pump (in  $\text{cm}^3/\text{rev}$ ).

pump	shaft	torque limit factor
PV016-PV023 PV028	N	17700
	D	17700
	M	17700
	K	20130
PV032-046 PV056&065	N	32680
	D	36380
	M	33810
PV063-PV092 PV110&125	K	40250
	N	77280
	D	72450
PV140-PV180 PV210	M	67620
	K	83720
	N	118400
	D	158760
	F	78750
PV270	G	97650
	M	113400
	K	157500
	N	119000
	D	159700
	M	170100
	K	236250

Total torque factor of the combination =  
sum of individual torque factors of all pumps

Torque factor of any pump =  $p \times V_g$  (pressure in bar x displacement in  $\text{cm}^3/\text{rev}$ )

- 規格修改，本公司不另行通知
- Specification is subjected to change without notice.